

# Guidelines for Pavilion Modules (Type X)

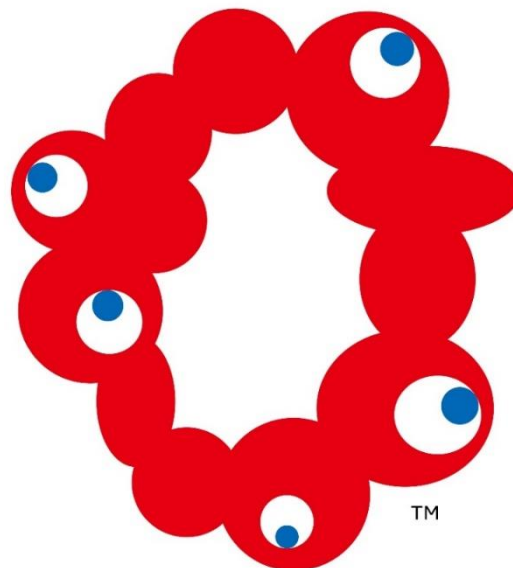

OSAKA, KANSAI, JAPAN

**EXPO**  
**2025**

## Table of Contents

### Abbreviation, Short Title, Unit, and Definition

Introduction .....	1
Purpose.....	1
Overview of This Guidelines Document.....	1
Control and Guide.....	2
Compliance with Laws and Regulations.....	2
Documents Provided by the Organiser .....	4
1. Overview of Overall Process from Internal/External Work etc. to Its Removal and Return of Exhibition Space.....	5
1-1. One Stop Shop (General Consultation Point) .....	5
1-2. Timeline .....	5
1-3. Procedural Flow of Approval and Authorisation.....	5
1-4. Design.....	7
1-5. Selection of Contractors .....	7
1-6. Requirements for Insurance for Interior/Exterior Work .....	7
1-7. Requirements for Commencement of Interior/Exterior Work (Permit for Commencement of Construction).....	7
1-8. Interior/Exterior Work etc.....	8
1-9. Removal of Interior/Exterior Decorations etc. and Exhibits.....	8
1-10. Documents to be submitted .....	8
2. Design Requirements.....	9
2-1. Pavilion Information.....	9
2-2. General Principles of Design .....	9
2-3. Planning Conditions.....	10
2-4. Design Consideration for Better Operation .....	13
2-5. Environmental Consideration .....	14
2-6. Submission of Design Plan.....	16
3. Requirements for Fire Prevention and Security .....	17
3-1. Fire Fighting Equipment, etc. ....	17

3-2. Security of Pavilions .....	17
3-3. Documents to be Submitted .....	18
4. Access to Utility Services .....	19
4-1. Preparation of the Infrastructure Supply Network .....	19
4-2. Requirements for Access to Utility Services.....	19
4-3. Documents to be Submitted .....	32
5. Rules and Management of Interior/Exterior Work etc. Within Expo Site .....	34
5-1. Construction Plan for Entire Expo Site.....	35
5-2. Construction Work Plan for Interior/Exterior Work etc.....	38
5-3. Security During Construction Work .....	42
5-4. Permit for Work Outside of Plot .....	44
5-5. Roads and Traffic Control .....	45
5-6. Security Measures When Constructing Concealed Spaces .....	47
5-7. Construction Progress Report .....	47
5-8. Documents to be Submitted .....	48
5-9. Reminders of Standards Referred to in This Chapter (Supplementary Information) .....	48
6. Securing of Occupation Safety and Health .....	49
6-1. Compliance with Laws and Regulations Concerning Occupational Safety and Health .....	49
6-2. Policy on the Sustainable Operation of the Expo .....	49
6-3. Development and Submission of Safety and Health Plans by Contractors .....	49
6-4. Occupational Safety and Health Management by Participants.....	49
6-5. Reporting on Accidents.....	49
6-6. Documents to be Submitted .....	49
6-7. Reminders of Standards Referred to in This Chapter (Supplementary Information) .....	50
7. Sustainability Efforts.....	51
7-1. Policy on Sustainability and Sustainable Procurement Code .....	51
7-2. Environmental Impact Assessment System (Environmental Assessment System) .....	51
7-3. Reminders of Standards Referred to in This Chapter (Supplementary Information) .....	51

<b>8. Information Management System and Compliance with Quality Control .....</b>	<b>52</b>
<b>8-1. Procedures and Methods of Notifications .....</b>	<b>52</b>
<b>8-2. Notification and Measures for Violation of Rules .....</b>	<b>53</b>
<b>8-3. Quality Control .....</b>	<b>54</b>
<b>8-4. Documents to be Submitted .....</b>	<b>54</b>
<b>8-5. Reminders of Standards Referred to in This Chapter (Supplementary Information) .....</b>	<b>54</b>
<b>9. Interior/Exterior etc. Removal Work and Return of Exhibition Space.....</b>	<b>55</b>
<b>9-1. Schedule-related Conditions in Interior/Exterior etc. Removal Work.....</b>	<b>55</b>
<b>9-2. Requirements for Commencement of Interior/Exterior etc. Removal Work .....</b>	<b>55</b>
<b>9-3. Interior/Exterior etc. Removal Work.....</b>	<b>56</b>
<b>9-4. Compliance with Occupational Safety and Health, Compliance and Quality Guarantee, and Sustainability Efforts.....</b>	<b>56</b>
<b>9-5. Discontinuing Use of Utility Services .....</b>	<b>56</b>
<b>9-6. Restoration to Original State and Return of Exhibition Space .....</b>	<b>56</b>
<b>9-7. Documents to be Submitted .....</b>	<b>56</b>
<b>9-8. Reminders of Standards Referred to in This Chapter (Supplementary Information) .....</b>	<b>57</b>
<b>10. Procedures for Notifications, Approvals, and Permits .....</b>	<b>58</b>
<b>10-1. Notifications by Architects, Contractors, and On-site Supervisors.....</b>	<b>58</b>
<b>10-2. Points of Caution Concerning Documents to be Submitted .....</b>	<b>58</b>
<b>10-3. Approval for Design.....</b>	<b>58</b>
<b>10-4. Permit for Commencement of Construction.....</b>	<b>60</b>
<b>10-5. On-site Inspection.....</b>	<b>60</b>
<b>10-6. Procedures for Construction Completion and User’s Permit .....</b>	<b>60</b>
<b>10-7. Permit for Interior/Exterior etc. Removal Work .....</b>	<b>61</b>
<b>10-8. Procedures for the Completion of Interior/Exterior etc. Removal Work .....</b>	<b>61</b>
<b>Supplementary Information.....</b>	<b>62</b>
<b>List of laws and regulations, ordinances, and standards .....</b>	<b>62</b>
<b>List of notifications to respective government bodies .....</b>	<b>65</b>

## Abbreviation, Short Title, Unit, and Definition

Abbreviation/Short Title	Official Name
BIE	Bureau International des Expositions
BIM	Building Information Modeling
BoH	Back of the house
EPS	Electric Pipe Space/Shaft
FoH	Front of the house
Unit	Official Name
Ha	Hectare
km	Kilometre
m	Metre
m <sup>2</sup>	Square metre
kW	Kilo watt
%	Percent
kVA	Kilovolt-ampere
Hz	Hertz
Term	Definition
The Expo	Expo 2025 Osaka, Kansai, Japan that is scheduled to be held from the 13th of April to the 13th of October, 2025 in Osaka, Japan
Laws and Regulations	The Convention; the General Regulations; the Special Regulations; the laws of Japan; government ordinances; ministry ordinances; government notifications and notices; ordinances, rules and regulations of local governments; Guidelines, supplementary instructions and directives on administrative procedures, documents to be submitted, the details of rights and responsibilities of Participants and the Organiser and other items issued by the Organiser pursuant to the General Regulations and Special Regulations
General Regulations	The General Regulations included in Chapter 8 of the Registration Dossier approved at the 167th General Assembly of the BIE
Special Regulations	The Special Regulations set out in Article 34 of the General Regulations
Site Master Plan	A detailed plan that presents the overview of various property elements, spaces, buildings and other facilities within the Expo Site
Pavilions	Buildings in which Official Participants and Non-official Participants present their exhibitions, which include: Type-A (Self-Built) Pavilions, Type B (Organiser-Built (Module)) Pavilions, Type C (Organiser-Built Shared) Pavilions and Type X (Organiser-Built (Module)), as well as any space related to the buildings that are directly under their control
Type-A (Self-Built) Pavilions	Buildings/structures that the Official Participants and Non-official Participants design and build on the Plot assigned to them by the Organiser
Type- B (Pavilion Modules)	Buildings built by the Organiser and rented to the Official Participants, who can make their own interior and exterior arrangements and install their exhibits
Type-C (Shared Pavilions)	Buildings built by the Organiser and offered to the Official Participants, who can arrange the space allocated to them and install their exhibits therein
Type- X (Pavilion Modules)	Buildings built by the Organiser and rented to the Official Participants, who can make their own interior and exterior arrangements, outbuilding and install their exhibits
Expo Site	All areas used and administered by the Organiser as the venue for the operation of the Expo
Exhibition Space	The areas which the Organiser assigns to Participants according to their Participation Contracts.
One Stop Shop (General Consultation Point)	The staffed service points set up and operated by the Organiser for the purpose of centrally handling all submissions and applications from Official Participants and providing advice and other support with the help of the Participant Portal, to ensure that the Official Participants are able to smoothly pursue their activities and work in relation to the Expo

The online portal for the Official Participants	An online portal that enables smooth communication between the Official Participants and One Stop Shop
Organiser	The Japan Association for the 2025 World Exposition, which was designated by the Minister of Economy, Trade and Industry on the 31st of May, 2019 to carry out tasks relating to the preparation and operation of the Expo, in accordance with the “Act on Special Measures Necessary for Preparing for and Managing of the International Exposition in 2025” and certified as a public interest incorporated association on the 21st of October, 2019
Participants	Official Participants and Non-official Participants. Official Participants means foreign governments and international organisations that have accepted the formal invitation from the Government of Japan to participate in the Expo. Non-official Participants means those who were authorised by the Commissioner General of the Exhibition to participate in the Expo outside the sections of the Official Participants
Communication and Coordination Council	A body that enables smooth coordination, etc. at the Expo Site where multiple construction works are implemented at the same time
General Contractor	A construction company that oversees and manages the Communication and Coordination Council that is established by the Organiser.
Related Institutions	Institutions that handle procedures in relation to construction work and design pursuant to the relevant Laws and Regulations in Japan
Application for a Building Permit	It is set out in Article 6 of the Building Standards Act. When any building is intended to be constructed, prior to the commencement of the related construction, the building owner shall submit an application for confirmation that the plan concerned conforms to the provisions related to building regulations and obtain the said confirmation from a building official.
Permit for Commencement of Interior/Exterior Work etc.	A permit issued by the Organiser to Participants to approve of the commencement of construction in accordance with the approved design submitted by the designer
Final Inspection	An inspection by a building official as set out in Article 7 of the Building Standards Act as well as an inspection by the Organiser upon the completion of the construction work
Certificate of Final Inspection	It is set out in Article 7, Paragraph (5) of the Building Standards Act. A certificate that is issued by the building official when he/she has conducted the Final Inspection set out in Article 7 of the Building Standards Act and confirmed that the relevant building conforms to the provisions related to building regulations
Certificate of Completion	A certificate that is issued by the Organiser only after a Participant has completed the interior/exterior decoration work which then passes the Organiser’s Final Inspection that the said Participant applies for
User’s Permit	A permit that is issued only after a Participant has completed all of the exhibition-related work and installed all the exhibits which then passes the Organiser’s inspection that the said Participant applies for
Interior/Exterior etc.	Interior/exterior, outbuilding (amenities external to building) and exhibits
Permit for Commencement of Interior/Exterior etc. Removal Work	The Organiser’s approval which a Participant shall obtain to commence interior/exterior, etc. removal work
Return of Exhibition Space	A procedure for Participants’ return of Exhibition Spaces to the Organiser after they have completed their interior/exterior etc. removal work
Attestation of Return of Exhibition Space	An attestation with which the Organiser provides a Participant when the Organiser confirms Exhibition Space of the Participant concerned is restored following the return of the Exhibition Space
JAS	Japanese Agricultural Standard. A standard to provide agricultural, forestry, fisheries and livestock products with quality assurance, pursuant to the Law Concerning Standardization, etc. of Agricultural and Forestry Products

JIS	Japanese Industrial Standards. Japanese national standards pursuant to the Industrial Standardization Act, which defines specifications and measurement of industrial products in Japan
Environmental Impact Assessment Document	A document prepared by the Organiser that presents the results of its research, forecast, and assessment based on the environmental impact assessment system and describes its measures put in place for environmental conservation
Policy on the Sustainable Operation of the Expo	A policy established by the Organiser to realise the Expo that takes account of sustainability
Sustainable Procurement Code	A code established by the Organiser that defines standards and methods, etc. to ensure that any related procurement activity complies with the Laws and Regulations; prevents environmental problems such as global warming and resource depletion and the infringement of human/labour rights; promotes equitable business practices; and invigorates local communities in order to achieve the Expo that takes account of sustainability
Fire Fighting Equipment, etc.	Equipment, etc. that are set out in Article 17 of the Fire Service Act
Utilities	Infrastructure-related facilities such as a water supply system, electricity, a sewage system (sewage and rainwater drainage), communication wiring, fire alarms, and cooling water

## Introduction

This Guidelines document describes requirements to be fulfilled by Participants when they carry out the interior/exterior decoration work, outbuilding work, and installation of their exhibits (hereinafter referred to as “Interior/Exterior Work etc.”) as well as the removal works of the interior and exterior decorated, the outbuildings maintained, and the exhibits installed by the Participants (hereinafter referred to as “Interior/Exterior etc. removal work” in relation to Pavilion Module (Type X) that are constructed by the Organiser for the Expo and rented to the Participants. It also describes the arrangements and other requirements applicable to the planning and implementation of the project and the management to be carried out by the Organisers.

The Pavilion Type X Modules are constructed by the Organiser, with which to provide Participants as their Pavilions. The Participants will rent the Pavilions, decide on exhibition content and create their own Exhibition Spaces by preparing exhibition equipment and exhibits. The Pavilions will be equipped with utilities, including a sewage system, rainwater drainage, service water, electricity and communication wiring while it is Participants’ responsibility to connect their equipment to the utility systems.

Note that the Organiser is expected to prepare “Supplemental Guidelines for Type X pavilions (tentative name)” separately. Participants shall observe the rules given by this document when implementing their Interior/Exterior work etc..

## Purpose

The purposes of this guidelines document are as follows:

- To provide specific guidelines concerning the planning conditions and other requirements when Participants design their Interior/Exterior Work etc..
- To provide clear guidance to enable the smooth implementation of the Interior/Exterior Work etc. and Interior/Exterior etc. removal work while many contractors execute work at the Expo Site at the same time.
- To explain the flow of the Interior/Exterior Work etc. of Pavilions and clarify requirements and procedures to be followed.
- To comply with what is stated in the Environmental Impact Assessment Document and ensure that Interior/Exterior Work etc. and Interior/Exterior etc. removal work take account of sustainability. What is set out in this Guidelines document supplements Special Regulation No. 4.

## Overview of This Guidelines Document

This Guidelines document consists of the following Chapters:

Chapter 1: Overview of Overall Process from Interior/Exterior Work etc. to Interior/Exterior etc. removal and Return of Exhibition Space

It defines requirements at each phase from the Interior/Exterior Work etc. of a Pavilion to Interior/Exterior etc. removal that the Organiser requires that Participants satisfy.

Chapter 2: Design Requirements

It defines planning conditions and other requirements concerning Interior/Exterior Work etc..

Chapter 3: Requirements for Fire Prevention and Security

It defines required Fire Fighting Equipment, etc. for fire prevention and security as well as requirements for security of Pavilions.

Chapter 4: Access to Utility Services

It defines requirements for access to utility services such as a water supply system, a sewage system (sewage and rainwater drainage), electricity, communication wiring, and cooling water.

Chapter 5: Rules and Management of Interior/Exterior Work etc. Within Expo Site

It defines and explains rules on Interior/Exterior Work etc. of Pavilions within the Expo Site and requirements and recommendations for the work management with the aim of supporting Participants during the work implementation.

Chapter 6: Securing of Occupation Safety and Health

It defines requirements for safety, hygiene, and working environment at the construction sites.

Chapter 7: Sustainability Efforts



It describes sustainability efforts and the environmental impact assessment system (environmental assessment system).

Chapter 8: Information Management System and Compliance with Quality Control

It defines an information management system that the Participants shall establish as well as the procedures of communication and requirements for quality control.

Chapter 9: Interior/Exterior etc. removal Work and Return of Exhibition Space

It defines requirements for procedures and rules in relation to interior/exterior etc. removal work and return of Exhibition Space.

Chapter 10: Procedures for Notifications, Approval and Permits

It defines requirements for key procedures pursuant to this Guidelines document and the relevant Laws and Regulations in Japan.

## Control and Guide

This document provides two types of indices—Control or Guide—to help Participants to implement Interior/Exterior Work etc. of their Pavilions and Interior/Exterior etc. removal work in compliance with this Guidelines document. The Organiser will also use these indices when it evaluates documents submitted by Participants.

Alphanumeric codes are used to designate Control and Guide.

**C-000 Control** defines requirements that Participants shall comply with and defines requirements as well as what is restricted or prohibited when planning and implementing the construction and Interior/Exterior etc. removal work of their Pavilions.

**G-000 Guide** indicates the Organiser's recommendation to Participants to ensure that the construction and Interior/Exterior etc. removal work of their Pavilions per se is in alignment with the purposes and objectives of the Expo.

## Compliance with Laws and Regulations

Participants shall perform the Interior/Exterior Work etc. of their Pavilions in compliance with relevant Japanese Laws and Regulations, prefectural or municipal ordinances of Osaka, and other Laws and Regulations.

> Building Standards Act and Order for Enforcement of the Act

(Building Standards Act) <https://elaws.e-gov.go.jp/document?lawid=325AC0000000201>(Order for Enforcement) <https://elaws.e-gov.go.jp/document?lawid=325CO0000000338>

> Act on Architects and Building Engineers and Order for Enforcement of the Act

(Act on Architects and Building Engineers) <https://elaws.e-gov.go.jp/document?lawid=325AC1000000202>  
(Order for Enforcement) <https://elaws.e-gov.go.jp/document?lawid=325CO0000000201>

> Fire Service Act and Order for Enforcement of the Act

(Fire Service Act) <https://elaws.e-gov.go.jp/document?lawid=323AC1000000186>  
(Order for Enforcement) <https://elaws.e-gov.go.jp/document?lawid=336CO0000000037>

> Construction Business Act and Order for Enforcement of the Act

(Construction Business Act) <https://elaws.e-gov.go.jp/document?lawid=324AC0000000100>  
(Order for Enforcement) <https://elaws.e-gov.go.jp/document?lawid=331CO0000000273>

> Labor Standards Act and Ordinance for Enforcement of the Act

(Labor Standards Act) <https://elaws.e-gov.go.jp/document?lawid=322AC0000000049>(Regulation for Enforcement) <https://elaws.e-gov.go.jp/document?lawid=322M40000100023>

> Industrial Safety and Health Act, Order for Enforcement of the Act, and Ordinance on Industrial Safety and Health

(Industrial Safety and Health Act) <https://elaws.e-gov.go.jp/document?lawid=347AC0000000057>  
(Order for Enforcement) <https://elaws.e-gov.go.jp/document?lawid=347CO0000000318>

(Regulation) <https://elaws.e-gov.go.jp/document?lawid=347M50002000032>> Construction Material

Recycling Act and Order for Enforcement of the Act

(Construction Material Recycling Act) <https://elaws.e-gov.go.jp/document?lawid=412AC0000000104>  
(Order for Enforcement) <https://elaws.e-gov.go.jp/document?lawid=412CO0000000495>

> Waste Management and Public Cleansing Act (Waste Management Act) and Order for Enforcement of the Law

(Waste Management Act) <https://elaws.e-gov.go.jp/document?lawid=345AC0000000137>

(Order for Enforcement) <https://elaws.e-gov.go.jp/document?lawid=346CO0000000300>> Basic Act on the Environment

(Basic Act on the Environment) <https://elaws.e-gov.go.jp/document?lawid=405AC0000000091>

> Air Pollution Control Act and Order/Regulation for Enforcement of the Act

(Air Pollution Control Act) <https://elaws.e-gov.go.jp/document?lawid=343AC0000000097>

(Order for Enforcement) <https://elaws.e-gov.go.jp/document?lawid=343CO0000000329>

(Regulation for Enforcement) <https://elaws.e-gov.go.jp/document?lawid=346M50000500001>

> Soil Contamination Countermeasures Act and Order/Regulation for Enforcement of the Act

(Soil Contamination Countermeasures Act) <https://elaws.e-gov.go.jp/document?lawid=414AC0000000053>

(Order for Enforcement) <https://elaws.e-gov.go.jp/document?lawid=414CO0000000336>

(Regulation for Enforcement) <https://elaws.e-gov.go.jp/document?lawid=414M60001000029>

> Noise Regulation Act and Order/Regulation for Enforcement of the Act

(Noise Regulation Act) <https://elaws.e-gov.go.jp/document?lawid=343AC0000000098>

(Order for Enforcement) <https://elaws.e-gov.go.jp/document?lawid=343CO0000000324>

(Regulation for Enforcement) <https://elaws.e-gov.go.jp/document?lawid=346M50014d00001>> Vibration

Regulation Act and Order/Regulation for Enforcement of the Act

(Vibration Regulation Act) <https://elaws.e-gov.go.jp/document?lawid=351AC0000000064>

(Order for Enforcement) <https://elaws.e-gov.go.jp/document?lawid=351CO0000000280>(Regulation for Enforcement) <https://elaws.e-gov.go.jp/document?lawid=351M50000002058>

> Act for Promoting Easily Accessible Public Transportation and Facilities for the Aged and the Disabled (Barrier-Free Act)

and Order/Regulation for Enforcement of the Act

(Barrier-Free Act) <https://elaws.e-gov.go.jp/document?lawid=418AC0000000091>(Order for Enforcement) <https://elaws.e-gov.go.jp/document?lawid=418CO0000000379>

(Regulation for Enforcement) <https://elaws.e-gov.go.jp/document?lawid=418M60000800110>

> Landscape Act and Order/Regulation for Enforcement of the Act

(Landscape Act) <https://elaws.e-gov.go.jp/document?lawid=416AC0000000110>

(Order for Enforcement) <https://elaws.e-gov.go.jp/document?lawid=416CO0000000398>(Regulation for Enforcement) <https://elaws.e-gov.go.jp/document?lawid=416M60000800100>

> Act on the Measures by Large-Scale Retail Stores for Preservation of Living Environment and Order/Regulation for Enforcement of the Act

(Act on the Measures by Large-Scale Retail Stores for Preservation of Living Environment) <https://elaws.e-gov.go.jp/document?lawid=410AC0000000091>(Order for Enforcement) <https://elaws.e-gov.go.jp/document?lawid=410CO0000000327>

(Regulation for Enforcement) <https://elaws.e-gov.go.jp/document?lawid=411M50000400062>> Entertainment Facilities Act and Regulation for Enforcement of the Act

(Entertainment Facilities Act) <https://elaws.e-gov.go.jp/document?lawid=323AC0000000137>

(Regulation for Enforcement) <https://elaws.e-gov.go.jp/document?lawid=323M40000100029>> Osaka

Prefectural Ordinance on the Enforcement of the Building Standards Act and Detailed Regulations

(Ordinance) [https://www.pref.osaka.lg.jp/houbun/reiki/reiki\\_honbun/k201RG00000834.html](https://www.pref.osaka.lg.jp/houbun/reiki/reiki_honbun/k201RG00000834.html)

(Detailed Regulations) [https://www.pref.osaka.lg.jp/houbun/reiki/reiki\\_honbun/k201RG00000835.html](https://www.pref.osaka.lg.jp/houbun/reiki/reiki_honbun/k201RG00000835.html)> Osaka Prefectural Ordinance on Welfare Communities and Regulation for Enforcement of the Ordinance

(Ordinance) [https://www.pref.osaka.lg.jp/houbun/reiki/reiki\\_honbun/k201RG00000861.html](https://www.pref.osaka.lg.jp/houbun/reiki/reiki_honbun/k201RG00000861.html)

(Regulation for Enforcement) [https://www.pref.osaka.lg.jp/houbun/reiki/reiki\\_honbun/k201RG00000862.html](https://www.pref.osaka.lg.jp/houbun/reiki/reiki_honbun/k201RG00000862.html)>

Osaka Prefectural Ordinance on Maintenance of Living Conditions and Regulation for Enforcement of the Ordinance

(Ordinance) [https://www.pref.osaka.lg.jp/houbun/reiki/reiki\\_honbun/k201RG00000392.html](https://www.pref.osaka.lg.jp/houbun/reiki/reiki_honbun/k201RG00000392.html)

(Regulation for Enforcement) [https://www.pref.osaka.lg.jp/houbun/reiki/reiki\\_honbun/k201RG00000393.html](https://www.pref.osaka.lg.jp/houbun/reiki/reiki_honbun/k201RG00000393.html)>  
Osaka Municipal Ordinance on the Enforcement of the Building Standards Act and Regulation for Enforcement of the Ordinance

- > Osaka Municipal Ordinance on Fire Prevention and Regulation for Enforcement of the Ordinance
- > Osaka Municipal Government Guidelines for Accessible Urban Planning

<https://www1.g-reiki.net/reiki37e/reiki.html> \* Please refer to the Osaka municipal code of regulations.

Furthermore, Participants shall comply with, and refer to various Guidelines documents, including this Guidelines document, and materials that are provided by the Organiser, or other standards, etc. that are relevant to what Participants plan to carry out.

### **Documents Provided by the Organiser**

Participants shall perform the work on their Pavilions in compliance with the documents below. Please refer to Chapter 7 for further information.

- Environmental Impact Assessment Document
- Policy on the Sustainable Operation of the Expo
- Sustainable Procurement Code

## 1. Overview of Overall Process from Internal/External Work etc. to Interior/Exterior etc. Removal and Return of Exhibition Space

This Chapter defines requirements at each phase from the Interior/Exterior Work etc. of a Pavilion to the Interior/Exterior etc. removal thereof that the Organiser requires that Participants satisfy.

### 1-1. One Stop Shop (General Consultation Point)

The Organiser will set up a One Stop Shop that centrally supports procedures at a variety of stages from the preparation phase of the exhibition through the removal of building materials after the Expo to assist Official Participants.

The One Stop Shop (General Consultation Point) consists of an online Participant Portal and staffed service points and handles requests, inquiries, applications and demands from Official Participants and provides necessary services.

- Responding to technical inquiries;
- Handling the procedures for design and construction work specified in this Guidelines document; and
- Offering consultation on the procedures required by the Related Institutions in Japan.

### 1-2. Timeline

**C-001** Participants shall implement their plan in accordance with the following timeline:

Please note that the average lead time from document submission to approval and the number of days to the deadlines described in this Guidelines document hereafter refer to the number of days exclusive of Saturdays, Sundays, national holidays, and other day-offs that the Organiser specifies.

(Legend: ◆ Required procedure ◇ Deadline)

- ◆ First submission (the general Design Plan)
- ◆ Second submission (the final Design Plan)
- ◇ Handover of the allocated Exhibition Space by the Organiser: To be notified separately
- ◇ Interior/exterior decoration etc. and final finishing work: To be completed by the 13th of March, 2025
- ◆ Completion of Interior/exterior decoration etc. (Certificate of Completion, User's Permit)
- ◇ The Expo period: From the 13th of April to the 13th of October, 2025
- ◆ Permit for Commencement of Interior/Exterior etc. Removal Work
- ◇ Return of Exhibition Space: To be completed by the 13th of January, 2026

**C-002** Participants shall, whenever they change the work schedule they submitted, submit updated work schedule to the Organiser via the Participant Portal. The work schedule shall describe the details of their Interior/Exterior Work etc. and Interior/Exterior etc. removal work.

**C-003** Participants shall have signed the Participation Contract before the Organiser hands Exhibition Spaces over to them.

### 1-3. Procedural Flow of Approval and Authorisation

Participants shall apply for required permission and inspection at each phase in accordance with the flow shown in Figure 1.1. For the details of the procedures, please refer to Chapter 9.

Figure1.1 Flow of Approval and Authorisation

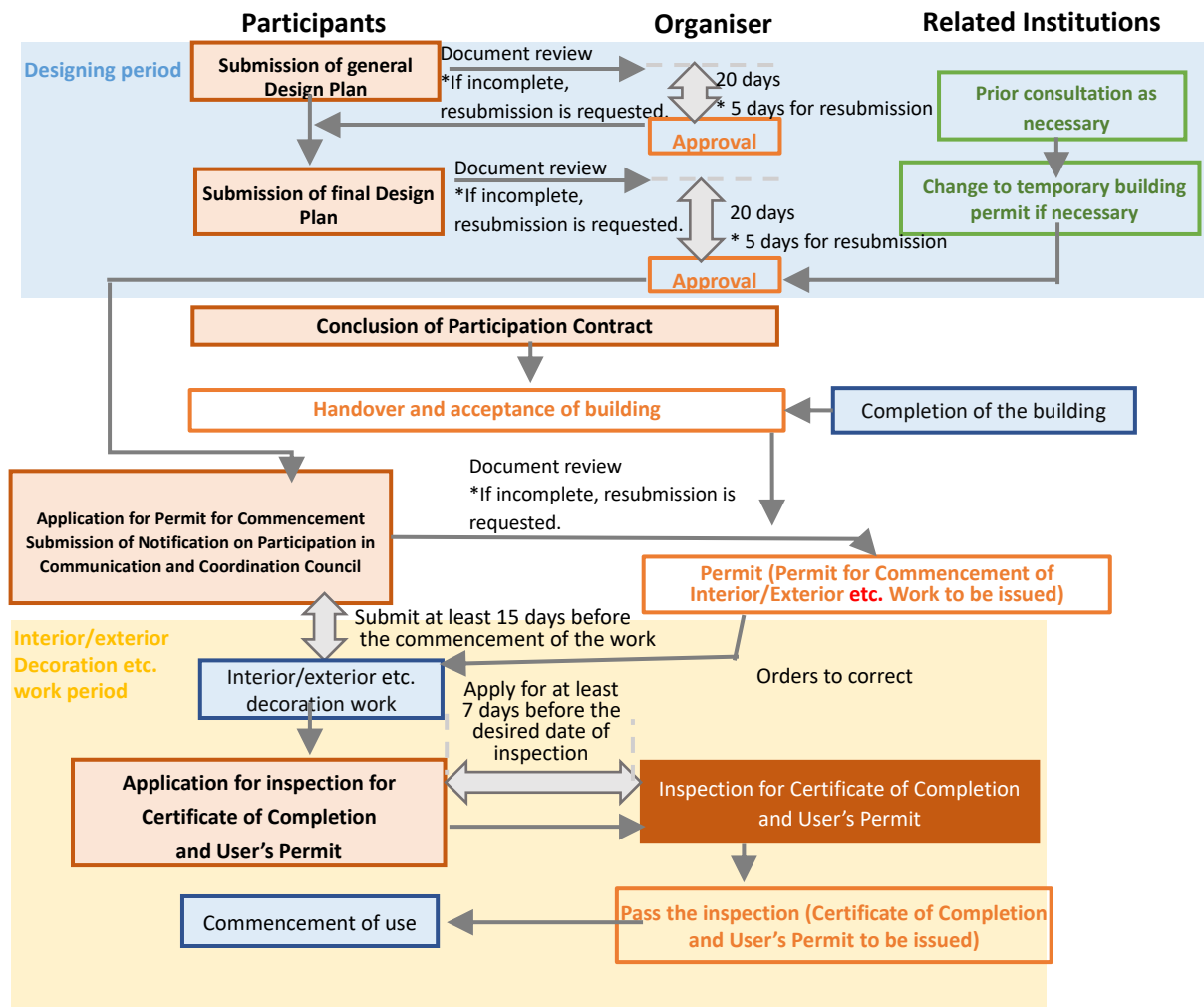

**The Expo period (from the 13th of April to the 13th of October, 2025)**

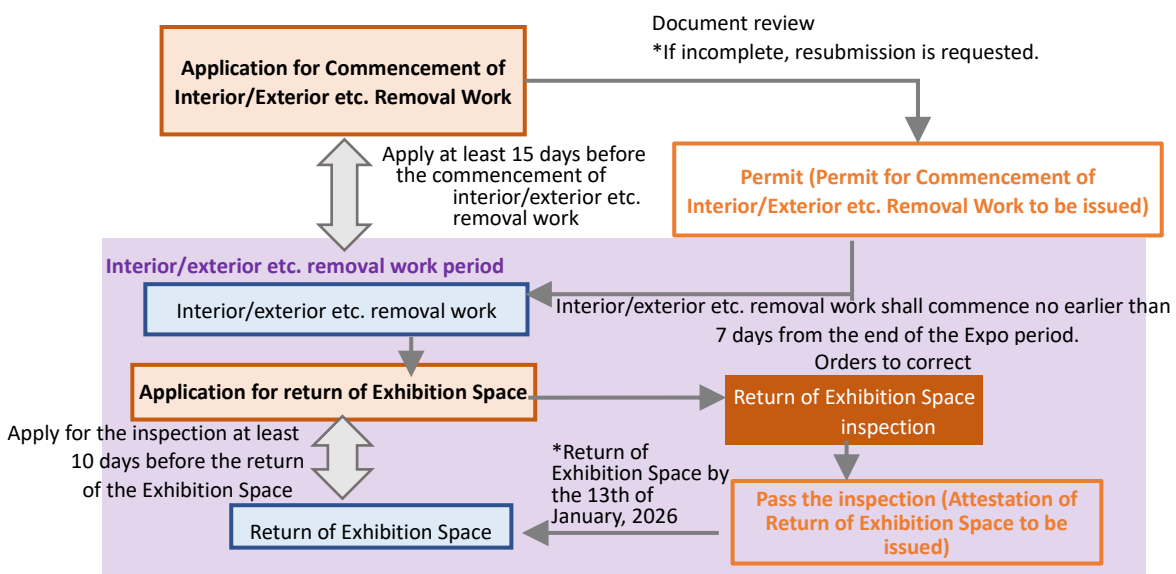

## 1-4. Design

Please refer to Chapter 2: Design Requirements for requirements for design, the Pavilion Sheet, and the submission of Design Plans.

**C-004** Pavilions will be handed over after the Organiser has obtained the Temporary Building Permit, Certificate of Completion for Confirmation, and Certificate of Final Inspection. Should the Interior/Exterior etc. work to be implemented by a Participant necessitate a change to its temporary building permit, the Participants shall be required to submit the document set forth in Chapter 10 to the Organiser, who will handle the procedures for changes after the granting of temporary building permit.

## 1-5. Selection of Contractors

When Participants look for contractors, they may choose ones from the supplier list for the Official Participants.

**C-005** In such a case, Participants shall appoint contractors that have the permits necessary to carry out the Interior/Exterior Work etc. and employ qualified staff. The Participants shall also appoint field supervisors.

**C-006** Participants shall submit the information of the appointed contractors and field supervisors to the Organiser via the Participant Portal at least 15 days before the commencement of the work.

## 1-6. Requirements for Insurance for Interior/Exterior Work etc.

**C-007** All the contractors shall take out following insurances for their construction work for the period of the work concerned. For further information, please refer to Special Regulation No. 8, which defines requirements for insurance, and the related Guidelines. Participants and their contractors shall have shared responsibility for insurance for the Participants' work.

- Workman's compensation
- Motor insurance
- Employment insurance
- Social insurance (health insurance and employees' pension insurance)
- Insurance in respect to construction, assembly, as well as civil engineering work on buildings, structures, and equipment and apparatus  
(including civil liability endorsement)

**C-008** Participants and their contractors shall submit the copy of the required insurance policies to the Organiser via the Participant Portal at least 15 days before the commencement of the work.

**G-001** It is desirable that contractors take out the following insurance. For further information, please refer to Special Regulation No. 8, which defines requirements for insurance, and the related Guidelines.

- Automobile insurance (to be taken out as a supplement to the motor insurance if necessary)
- Bond insurance
- Non-life insurance
- Labour accident compensation insurance (to be taken out as a supplement to the workman's compensation if necessary)
- Cyber risk insurance

## 1-7. Requirements for Commencement of Interior/Exterior Work etc. (Permit for Commencement of Construction)

**C-009** Participant shall obtain the Permit for Commencement of Interior/Exterior etc. Work from the Organiser via the Participant Portal. The application shall be made at least 15 days before the scheduled

commencement date of the construction work. The application shall be accompanied by required documents. For further information, please refer to Chapter 10.

### **1-8. Interior/Exterior Work etc.**

Participants may commence their decoration work only after the Permit for Commencement of Interior/Exterior Work etc. is issued by the Organiser. For further information, please refer to Chapter 10.

**C-010** Participants shall complete their interior /exterior etc. work by the designated dates specified in “1-2. Timeline” herein. The work schedule of the Organiser (for reference only) is available on the Participant Portal.

**C-011** Participant shall follow the rules and procedures specified by the Organiser for the customs clearance, and the transportation and handling of freight. For further information, please consult Special Regulation No. 7, the related Guidelines (“Guidelines for Handling of Freight” and “Guidelines for Customs Clearance Procedures”), and other relevant documents.

**C-012** Upon the completion of exhibit installation, Participants shall carry out trial and test operation and apply for an inspection to the Organiser to obtain the User’s Permit.

**G-002** It is desirable that Participants establish procedures for the trial and test operation. The Organiser may request that Participants should present the procedures to the Organiser.

### **1-9. Removal of Interior/Exterior Decorations etc. and Exhibits**

**C-013** Participants shall complete the removal of their interior/exterior decorations and other arrangements from their Pavilions, restore them to their original conditions, and return them to the Organiser by the designated dates specified in “1-2. Timeline” herein. For further information, please refer to Chapter 9.

**C-014** Participant shall follow the rules and procedures specified by the Organiser for the customs clearance, and the transportation and handling of freight. For further information, please consult Special Regulation No. 7, the related Guidelines (“Guidelines for Handling of Freight” and “Guidelines for Customs Clearance Procedures”), and other relevant documents.

### **1-10. Documents to be submitted**

The following are documents concerning this Chapter that the Organiser requires Participants to submit. The documents are to be submitted to the Organiser via the online portal for the Official Participants. Designated formats for documents to be submitted will be made available on the online portal for the Official Participants. Names of documents to be submitted:

- Notification of contractors and field supervisors (1-5)
- Notification of insurance taken (1-6)

## 2. Design Requirements

This Chapter explains requirements and other conditions for designing interior/exterior etc. arrangements of Pavilions.

- C-015** Participants may not implement their work in such a way as to interfere with the functions of buildings, facilities, and fixtures provided by the Organiser. If the interference is unavoidable, the Participant shall implement a corrective measure at its own cost.
- C-016** Changes and modification to the building provided by the Organiser shall require to meet the following conditions:
- Changes/modifications to the structure of the building are not permitted. Also, the changes/modifications shall be in compliance with laws of Japan, ordinances, and standards. Buildings which the Organiser constructed are registered as temporary buildings, issued with the Notification of Authorisation as well as the Certificate of Final Inspection pursuant to the Building Standards Act, keep in mind that interior/exterior work etc. shall be in compliance with above Laws and Regulations.
  - When extensions are built on the site, the building-to-land ratio shall be within 70% and, as a rule no buildings may be constructed in the setback area on the main lines of traffic side.
  - All the cost incurred by the changes/modifications (including designing, installation/application, and removal) shall be borne by the Participants.
  - The Participants shall be responsible for the design and implementation of the changes/modifications.

### 2-1. Pavilion Information

- C-017** Participants shall verify Pavilion specifications with the following drawings and other documents which the Organiser shall provide before designing their interior/exterior etc. arrangements. The language of the drawings, etc. to be provided will be Japanese.
- Architectural design drawings
  - Equipment drawings
  - Structural drawings
  - Documents submitted for the Application for a Building Permit (photocopies)
  - Documents submitted for the Application for Temporary Building Permit (photocopies)
  - Water supply, electricity supply and heat supply

### 2-2. General Principles of Design

From this section through to 4-3, guidelines detail requirements concerning the interior/exterior etc. designs of Pavilions.

#### 2-2-1. General Principles of Design

Participants may design the Pavilion space and the outbuilding in the plots and freely express culture, events, entertainment, resources, and other themes in alignment with the Expo Theme and Subthemes.

The Organiser shall hand the Pavilions over to Participants as their exclusive space for their exhibits and offices.

- C-018** Participants shall take necessary measures to appropriately manage and operate their Pavilions, including visitor services, access routes, security, fire fighting/disaster prevention, cleaning, and waste management.
- C-019** They shall also consider their designs to meet the conditions of their Pavilions and comply with the requirements concerning Interior/Exterior Work etc. and Interior/Exterior etc. removal work.
- G-003** It is recommended that the design will represent the buildings, landscape, culture, and natural resources of Participants' own countries aesthetically in alignment with the Theme and Subthemes of the Expo while forming a seamless view in the Expo Site.



- G-004** It is recommended that participants proactively use natural and reusable/recyclable materials and adopt sustainable structures and construction methods. (For further information, please refer to “2-5-2. Environmental Consideration: Promotion of Resource Recycling and 3Rs”)
- G-005** It is recommended that Participants plan their Pavilions with due consideration for universal design to ensure that everyone can benefit from comfort and security as they enjoy the Expo (For further information, please refer to “Universal Design Guidelines for Facility Implementation”)

## 2-3. Planning Conditions

Participants shall consult Table 2.1 and Table 4.4 for the specifications of the Pavilion buildings and equipment provided by the Organiser when considering interior, exterior, and exhibit installation plans. They shall also check drawings and other documents for details.

Note that the pavilions will have heat exchangers, various ducts, and other equipment as well as duct access chambers already installed, and these shall also be taken into account.

Participants shall also be required to comply with the “Supplemental Guidelines for Type X pavilions (tentative name)” which is to be prepared in the near future.

### 2-3-1. Building Exterior

- G-006** The grand roof (the ring) over the main route (Main Street) will have an aerial corridor, which offers visitors a panoramic view over the Pavilion buildings across the Expo site. Thus, it is recommended that Participants take into consideration to make the building exterior to form part of the overall landscape.

#### (1) Facade

- C-020** The buildings have decoration base materials (suspended railings) on the front exterior wall etc., on which decorations can be mounted up to the height of the wall. The decoration base has a load capacity of 98N/m<sup>2</sup>, thus heavy items that surpass this capacity limit cannot be mounted. Decorations may not be fixed on the exterior wall cladding panels. They shall be fastened on the base materials of the cladding panels. The decorative exterior walls of the building itself can only be decorated by painting or wrapping. For specifications of the decorative underlay material, see the drawings etc. provided separately.

#### (2) Doorways/service entrances

Every facade is designed with two doorways for visitors. On the BoH side, one service entrance is provided.

- C-021** These accesses may not be altered. Decorations and exhibitions that block the doorways are prohibited.
- C-022** Participants may not modify or otherwise make changes to the Pavilion doors, including their locking systems.
- C-023** The two doorways for visitors will be open at all times during the Expo opening hours as constant traffic of visitors is anticipated.

#### (3) Windows

- C-024** Erecting a wall, mounting a decoration, or installing exhibits in such a way that it covers the windows, shall be implemented in compliance with relevant Laws and Regulations.

#### (4) Rooves

- C-025** The building rooves may not be altered by mounting decorations, painting, applying wrapping, and other means.

### 2-3-2. Building Interior

#### (1) Ceiling

The ceilings are in the conventional style (not suspended ceilings). Participants may arrange their preferred ceiling over the existing one as long as it complies with relevant Laws and Regulations and does not adversely affect the structure or equipment of the building.

#### (2) Suspended exhibits

**C-026** The buildings provided by the Organiser is, in principle, unfit for fixing suspended exhibits on the rooves and ceilings. However, relatively light items, such as fabrics, curtains, and banners, may be attached provided that relevant Laws and Regulations are complied with. The Participants who implement such suspending decorations shall be required to provide appropriate protections for the roof and beams to prevent damaging them.

**C-027** The suspending load capacity of the ceiling is 200 N/m<sup>2</sup>. The Participants shall install decorations to the extent that they do not affect the structure and equipment.

### (3) Interior wall panel

Participants may erect interior wall panels as long as they comply with relevant Laws and Regulations and do not adversely affect the structure or equipment of the building.

### (4) Floors

**C-028** The reinforced concrete floor (trowel-finished; load capacity: 9.8 kN/m<sup>2</sup>) may be modified by Participants as long as the modification is in compliance with relevant Laws and Regulations and it does not adversely affect the structure etc. of the building. Not that sections of floors that are not in cast reinforced concrete may not be altered. To verify the areas of reinforced concrete floors, consult architectural drawings and related documents.

It shall be noted that it is prohibited to remove a section of, or drill holes in, the floor if these will result in cutting the steel mesh.

### (5) Equipment

The Organiser shall install equipment such as emergency lighting and emergency exit lights, alarm systems, fire-fighting equipment, and ventilation systems. Participants shall install other equipment as necessary. Before installing equipment, Participants shall consult this Section as well as Chapters 3 and 4. They shall also be required to verify the installation locations, sizes, and other details of the equipment provided by the Organiser in architectural drawings. Note that the Organiser may, if necessary, request Participants to submit the specifications of the equipment they have installed.

**C-029** Participants shall be required to implement grounding for their equipment as necessary for safety purposes.

**C-030** Where Participants install equipment and apparatus, they shall be required to consider providing secondary fall-preventive measures such as fixing wire in case of earthquakes.

### (6) Other

**C-031** As a rule, equipment or fittings that use gas stoves, boilers, or engines are not permitted for installation, unless necessary measures are implemented in the room in which these combustion-related units are used, including the evacuation routes for users and fire-protection system to prevent the spread of fire to adjacent rooms, provided that these measures are in compliance with Laws and Regulations.

## 2-3-3. Amenities External to Building

**C-032** The Participants may install outbuildings (e.g. plantings, monuments, stages, etc.) on the site. The Organiser shall conduct underground installation of drainpipes for building's rain water drainage. The Participants shall properly locate rain water gutters on the site and buried drainpipes and shall maintain them with respect to pavements, etc.

Figure 2.1 Building Exterior Layout Images

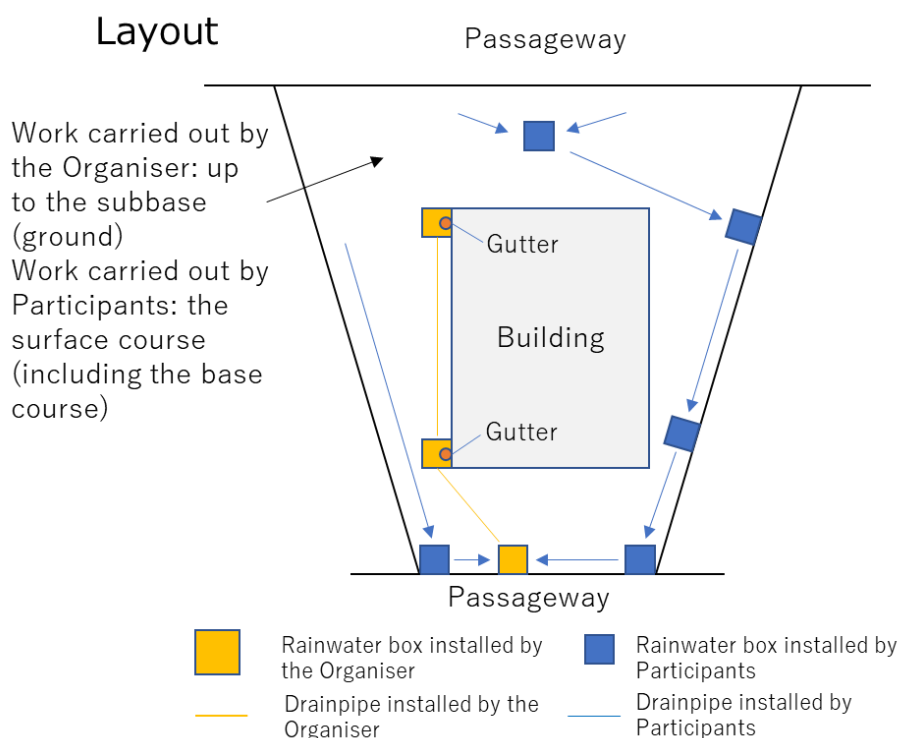

Table 2.1 Building work classification (relevant to Chapter 2)

Building parts		Work to be carried out by the Organiser	Work to be carried out by Participants
Amenities external to building		<ul style="list-style-type: none"> <li>- Path subbase</li> <li>- Underground installation of drainpipes for building's rain water drainage</li> </ul>	<ul style="list-style-type: none"> <li>• all after works at left (surface courses, monuments, benches, softscaping, etc.)</li> <li>- Street gutters and underground rainwater drainpipes on the plot</li> </ul>
Interior	Walls	<ul style="list-style-type: none"> <li>- Incomplete (no interior walls)</li> </ul>	<ul style="list-style-type: none"> <li>- Erecting interior wall panels allowed (as far as not affecting the building structure/equipment adversely)</li> </ul>
	Ceilings	<ul style="list-style-type: none"> <li>- In the exhibition area: conventional ceiling</li> <li>- Ceiling suspension load capacity: 200 N/m<sup>2</sup></li> </ul>	<ul style="list-style-type: none"> <li>- Fabrication of another layer of ceiling allowed (as far as not affecting the building structure/equipment adversely)</li> </ul>
	Floor	<ul style="list-style-type: none"> <li>- In the exhibition area: reinforced concrete, trowel finish with silicate concrete sealer</li> <li>- Load capacity: 9,800 N/m<sup>2</sup> (floor) and 9,000 N/m<sup>2</sup> (superstructure), seismic resistance: 5,900 N/m<sup>2</sup></li> </ul>	<ul style="list-style-type: none"> <li>- Finishes can be produced</li> <li>- Fixing of exhibits without affecting the building structure</li> </ul>

Exterior	Exterior walls	· Implemented by the Organiser (For materials, see drawings etc. provided)	- Decorations shall be fastened on the base materials of the cladding panels
	Eaves	- Implemented by the Organiser (For materials and installation position, see drawings etc. provided)	- No alteration allowed
	Base for fixing decorations	- Implemented by the Organiser (Load capacity: 98N/m <sup>2</sup> ) (in case of fixing banners and other light items)	- Decorations on the exterior walls
	Rooves	- Implemented by the Organiser: colour-painted galvanised steel sheets, twin skin roof cladding	- No alteration allowed
	Doorways	- Implemented by the Organiser	- No alteration allowed
	Windows	- Implemented by the Organiser ( material : Aluminium)	- No alteration allowed

#### 2-3-4. Conditions of Plot Boundary

**C-033** In order to secure the access of emergency vehicles and appropriate evacuation routes, participants shall not erect railings and fences without a break along the boundary at the front of the pavilion (a part facing the main line of flow (Main Street) or a plaza) and at the back thereof (a part facing the line of flow of service providers). In the case a participant intends to erect railings and fences, it shall ensure that the railings and fences have multiple entrances with adequate width. However, if it is necessary for the operation of pavilion and other purposes, erecting railings and fences along the boundary with adjacent plots is allowed.

**C-034** Participants shall design a landscape in harmony with public spaces at the front of the pavilion facing the main line of flow (Main Street) or a plaza.

**G-007** It is recommended that participants should cooperate and coordinate with the participant(s) to which the adjacent plot(s) are allocated.

## 2-4. Design Consideration for Better Operation

### 2-4-1. Queue Management

**C-035** If visitors of a pavilion are expected to stand in a queue, the queue shall be contained within the plot of the pavilion.

**G-008** It is recommended that participants should design a queue area based on the level-of-service D defined by J. J. Fruin.

**G-009** It is recommended that participants should adopt a reservation system to avoid a long queue.

**G-010** In order to provide visitors in the queue with comfortability and fun, it is recommended that participants should offer drinking fountains, places to rest (benches) and other services as well as give exhibition-related entertainment including the presentation on the pavilion and events.







	<b>A</b>	<b>B</b>	<b>C</b>	<b>D</b>	<b>E</b>	<b>F</b>
Level of Service						
Space (m <sup>2</sup> /pedestrian)	More than 3.2	2.3 ~ 3.2	1.4 ~ 2.3	0.9 ~ 1.4	0.5 ~ 0.9	Less than 0.5
Free flow of pedestrians	Free flowing	Minor conflicts	Some restrictions to speed	Restricted movement for most	Restricted movement for all	Shuffling movement for all

Figure: A level-of-service concept by J. J. Fruin

#### 2-4-2. Service Routes and BoH

- C-036** As a rule, carrying goods in and waste out of the pavilion shall take place before or after its opening hours..
- C-037** All BoH areas shall be hidden from the visitors' view and designed not to obstruct goods transportation. (Movement within the BoH area should not be impeded by curb-stones, steps, steep gradients, narrow doorways or other obstacles.)
- C-038** Waste shall be stored within the plot. The storage of waste shall have structure and size that can avoid the leakage of offensive odour and/or liquid and be established indoor.
- C-039** Hazardous waste is not allowed to be stored within the Plot. All of the waste shall be stored in the place hidden from the visitors' view.
- C-040** Pavilions shall be designed to include a driveway for emergency vehicles.
- G-011** It is recommended that warehouses built within the Exhibition Space keep at least a two-day worth stock of products and consumables except merchandise and short-shelf-life goods for food and drink services.

#### 2-4-3. Parking of Small Mobility Vehicles and Alike

- G-012** It is recommended that participants should secure a space where small mobility vehicles such as mobility scooters can be parked.

### 2-5. Environmental Consideration

#### 2-5-1. Energy and Global Environment

- C-041** Participants shall choose equipment and apparatus with high energy efficiency.
  - With regard to the apparatus covered by the Top Runner Programme, Participants shall choose ones that meet the programme's energy saving criteria (note that this does not apply to cases in which Participants introduce leased/reused apparatus to reduce waste).
- G-013** Adoption of renewable energy systems, such as solar power and wind power generation, is recommended.
- G-014** Adoption of an EMS (energy management system) is recommended to enable Participants monitor their energy use, for example, by applications (air conditioning, ventilation, lighting, hot-water supply, wall sockets, etc.) and by apparatuses.

- Participants are encouraged to visualise their energy use and make efforts to reduce energy consumption through efficient equipment operations.

**G-015** It is recommended to adopt materials and equipment with lower ozone depletion potential and global warming potential values.

**G-016** It is recommended to choose equipment with low NOx emissions\*<sup>2</sup>.

\* In deciding a heat insulator, air conditioner, freezer and other equipment they will use, participants shall consider whether the candidates comply with the specifications of ‘heat insulators (for public works),’ ‘air conditioners,’ etc. defined in the “Osaka Prefectural Policy on Green Procurement” and/or are certified to the Environmental Labels.

\*<sup>2</sup> If a participant plans to install equipment covered by the “Recommended Guidelines on Low NOx-type Small Burners” (the Ministry of the Environment of Japan) or “Recommended Guidelines for Reducing Nitrogen Oxide Emissions in Osaka Prefecture,” it shall comply with these guidelines.

### 2-5-2. Promotion of Resource Recycling and 3Rs

**G-017** Participants are expected to opt for recycled materials\* for their building materials.

**C-042** Participants shall adopt construction structure/methods that allow easy separation of scrap materials when demolishing the pavilion.

- Most of the exterior and interior materials shall be either easy to dismount or consist of a single material, and have recyclable structures or adopt installation methods that allow their recycling.

**C-043** Sanitary appliances shall be of a water-saving model. Participants shall fit key faucets with water restrictors as well as adopt water-saving equipment.

- For the selection of water-saving equipment, Participants shall consider the products with the Environmental Label certification\*<sup>2</sup>.

**G-018** It is recommended that Participants proactively pursue reuse of materials and equipment.

- Participants shall take into consideration scenarios for reuse after removal when developing their designs and make efforts to adopt reusable materials for interior decorations, which tend to become mixed waste\*<sup>3</sup> \*<sup>4</sup> \*<sup>5</sup>.

**G-019** Trees for outbuilding should be designed to be transplanted or relocated.

**G-020** It is recommended to opt for wood, paper, and other materials that easily regenerate in the natural environment. Concerning the use of wood in particular, use sustainable items\*<sup>6</sup> such as certified timbers.

**G-021** It is recommended that Participants avoid using materials with significant environmental footprint and those with low degradability\*.

**G-022** Use of lease or rental equipment and machines is recommended.

\*When deciding on materials to be used, Participants shall consider products certified by relevant certification schemes, such as the “Environmental Labels” and the “Osaka Prefecture Recycle Product Certification System.”

\*<sup>2</sup> With regard to the designated procurement items defined in the “Osaka Prefectural Policy on Green Procurement,” such as electronic automatic faucets, urinals, toilet bowls, etc., participants shall procure items complying with the Policy.

\*<sup>3</sup> Refer to the Construction Material Recycling Promotion Plan 2020 (the Ministry of Land, Infrastructure, Transport and Tourism of Japan) for the target emissions rates when setting own emission rate target.

\*<sup>4</sup> When reusing equipment and other items, give due consideration to the history of the items in question, methods of quality verification and evaluation, and their distribution system.

\*<sup>5</sup> Regarding wood materials, Participants shall consider their reuse potential bearing in mind that joint parts may not be reused.

\*<sup>6</sup> The legality and sustainability of wood can be verified by means of the certified wood programs, Chain of Custody certification, and similar certification programmes administered by local governments (refer to the “Act on Promoting the Distribution and Use of Legally Harvested Wood and Wood Products” as well as “Guideline for Verification on Legality and Sustainability of Wood and Wood Products” by the Forestry Agency of Japan).

### 2-5-3. Protection against the Heat

**C-044** Participants shall install sunshade devices such as blinds and pergolas in the queuing area.

**G-023** It is recommended that participants should reduce exhaust heat.

As a rule, participants should use cooling water supplied by the Organiser for air conditioning and avoid installing its own outdoor units as far as practically possible.

**G-024** It is recommended that participants should take precautions against the heat by implementing such measures as the adoption of water retentive pavement.

**G-025** It is recommended that participants should take precautions against the heat by utilising greenery such as creating the shade of trees and implementing wall-surface greening.

**G-026** It is recommended that participants should take precautions against the heat for visitors such as sprinkling of fine mist and/or water.

#### 2-5-4. Metering

**C-045** If Participants use utilities other than the cooling water and electricity supplied by the Organiser, such as propane gas, they shall monitor the amount of use by installing a meter or implementing other means.  
- The Participants shall report their consumptions when requested by the Organiser.

**C-046** If Participants install power generation facilities (including renewable energy and other power generation options), they shall monitor generated output by installing a meter or implementing other means.  
- The Participants shall report their power output when requested by the Organiser.

**G-027** If Participants utilises reclaimed water, it is recommended that they monitor the amount of use by installing a meter or implementing other means.  
- The Participants shall report their use when requested by the Organiser.

## 2-6. Submission of Design Plan

The following are documents concerning this Chapter that the Organiser requires Participants to submit. The documents are to be submitted to the Organiser via the online portal for the Official Participants. Designated formats for documents to be submitted will be made available on the online portal for the Official Participants. For details about the submission of a design plan, refer to Chapter 10: Procedures for Notifications, Approvals and Permits.

Names of documents to be submitted:

- First set of documents to be submitted
- Second set of documents to be submitted

### 3. Requirements for Fire Prevention and Security

This Chapter defines requirements for fire prevention and security. Participants shall comply with the rules set out in this Chapter as well as the relevant Laws and Regulations. Participants shall take responsibility for the security of their Pavilions. The Organiser will not accept any responsibility for the security of the Participants' Pavilions. Participants shall bear costs for fire prevention and security. Participants shall consider the requirements defined in this Chapter when they design their Pavilion.

#### 3-1. Fire Fighting Equipment, etc.

In Exhibition Spaces, Participants shall install and maintain Fire Fighting Equipment, etc. pursuant to technical standards defined by the relevant Laws and Regulations in order to provide the Pavilions with necessary fire-fighting functions, such as fire extinction, fire alarm, and evacuation, and follow procedures required by the Fire Department (please refer to the list of the relevant Laws and Regulations).

**C-047** The Organiser shall install the necessary fire-fighting equipment, etc. in accordance with the Fire Service Act, the Order for Enforcement of the Act, and Osaka Municipal Ordinance on Fire Prevention. In the event that the location of such equipment needs to be changed or expanded due to interior decoration work, the Participant shall install such equipment at his/her own expense. Participants shall cooperate in the maintenance of these fire-fighting equipment and other necessary procedures.

**C-048** On the interior side of the building, Participants shall not block the effective openings as a rule with walls or fixtures (exhibits) due to interior work, etc. If walls or fixtures (exhibits) are placed inside the opening, they cannot be counted as effective openings and are treated as no windows, which may require sprinklers, etc.

##### 3-1-1. Fire Fighting Equipment, etc.

The Organiser shall install the following fire fighting equipment, etc.:

- Fire extinguishers outdoor fire hydrants (which substitute indoor fire hydrants)

**C-049** Plan to ensure that decorations, wrapping, fencing, etc. do not interfere with outdoor fire hydrants installed by the organiser.

##### 3-1-2. Fire Alarm Equipment

The Organiser shall install a main receiver and detectors inside Exhibition Spaces to build automated fire alarm equipment within the Expo Site. Should Participants implement interior work to add ceilings, partition walls, or other features, they shall ensure that additional and repositioned detectors are connected to the main receiver installed by the Organiser so that the system is ready to output proxy fire signals to the mission-critical system of the automated fire alarm equipment in the central control facility.

##### 3-1-3. Fire Report Apparatus

The Organiser shall install one unit of IP telephone which able to call 119 to report a fire, instead of a fire alarm equipment for reporting the outbreak of a fire to a fire fighting authority. Please refer to "Chapter 4: 4.2.6 Telecommunications" for the details of telecommunication infrastructure used by IP telephones.

### 3-2. Security of Pavilions

#### 3-2-1. Security Cameras

**C-050** Participants shall put all the spaces used by general public visitors and all the entrances of their facilities (including entrances for staff) within their Exhibition Spaces under the surveillance of security cameras.

**C-051** The security cameras referred to in the preceding item shall be designed to have ability to confirm the safety of visitors. The security cameras shall have a function of video recording around the clock or motion-activated recording that is stored in recording apparatus or on the cloud and maintain the record for two weeks or more. Participants shall clarify the location and other information of the security cameras when submitting their Design Plans to the Organiser for its approval.

**C-052** When the Organiser and/or Related Institutions demand that Participants should allow them to watch video recorded by the security cameras or provide them with such video, Participants shall comply with their instructions.



**C-053** Participants shall take due care of video recorded by the security cameras in handling it from the privacy protection perspective.

### 3-2-2. Other Requirements for Safety and Security

**C-054** Participants shall configure all the security-related equipment to be supplied with backup electricity from an uninterrupted power supply (UPS) that runs for at least 30 minutes to prepare for a power outage.

**G-028** It is desirable that Participants introduce an intrusion detection system in the areas where precious goods are stored or exhibited.

**C-055** If and when the intrusion detection system puts out an alert, Participants shall report it to the Organiser. Participants shall take responsibility for insuring their asset and the security thereof.

**C-056** Participants shall not establish areas to which anyone other than the Participant concerned cannot enter (hereinafter referred to as Restricted Areas). If a Participant cannot follow the rule in the preceding item, the Participant concerned shall clarify the Restricted Areas when submitting their Design Plans to the Organiser for its approval.

**C-057** Participants shall, when bringing equipment or materials to be installed/used in the Restricted Areas into the Expo Site, obtain the permission of the Organiser in advance.

**C-058** Before a Pavilion with the Restricted Areas referred to in C-056 is closed, the Organiser may have a party it designates carry out inspection on site or in the manufacturing facilities, etc. of the relevant equipment and materials. Participants shall follow the Organiser's demand. In such a case, Participants shall bear costs for the inspection.

### 3-3. Documents to be Submitted

The following are documents concerning this Chapter that the Organiser requires Participants to submit. The documents are to be submitted to the Organiser via the online portal for the Official Participants. Designated formats for documents to be submitted will be made available on the online portal for the Official Participants.

Names of documents to be submitted:

- [If necessary] Application form for the establishment of Restricted Areas (3-2-2)
- [If necessary] Application form for bringing equipment or materials into Restricted Areas (3-2-2)

## 4. Access to Utility Services

Utility services will be provided to all Pavilions before the exposition is held. After obtaining relevant approvals from the Organiser, Participants will access and activate the utilities. The Organiser will notify Participants each time respective Utilities become available.

### 4-1. Preparation of the Infrastructure Supply Network

The Organiser will provide Participants with details on Utility allotment as well as details on Utility access such as location, size, level, and materials. Please refer to this Chapter and information available on the online portal for the Official Participants for further details on the access to Utilities. Similarly, for details on temporary Utility supply, please refer to Chapter 5.

**C-059** If the Organiser cannot prepare permanent Utility services by the time Participants need to access them, the Participants shall arrange for the temporary Utility services on their own until the permanent Utility services start operating.

### 4-2. Requirements for Access to Utility Services

Before activating Utilities within Exhibition Spaces, Participants shall confirm the supply period with the Organiser and obtain appropriate approvals.

Participants shall conclude a contract with the Organiser for electricity, water, sewerage (waste water) and chilled water, and a contract with a Utility service vendors for gas and telecommunications. Participants are responsible for paying fee of the connection to the Utility.

**C-060** In the event the Participants' use of Utility services affect the Utility supply network installed by the Organiser, the Participants shall bear costs for the effects caused.

#### 4-2-1. Water

The Organiser will install water supply locations and water supply networks, connecting the supply facilities situated near the buildings and the passageways in the site to the water supply mains.

- Normal time: 0.3 MPa or more at the end of the water pipe
- Emergency: 0.4 MPa or more at the end of the water pipe  
(Emergency refers to the use of an outdoor fire hydrant in the event of a fire.)

Figure 4.1 Water/sewage service demarcation point near on-site passageway boundary lines

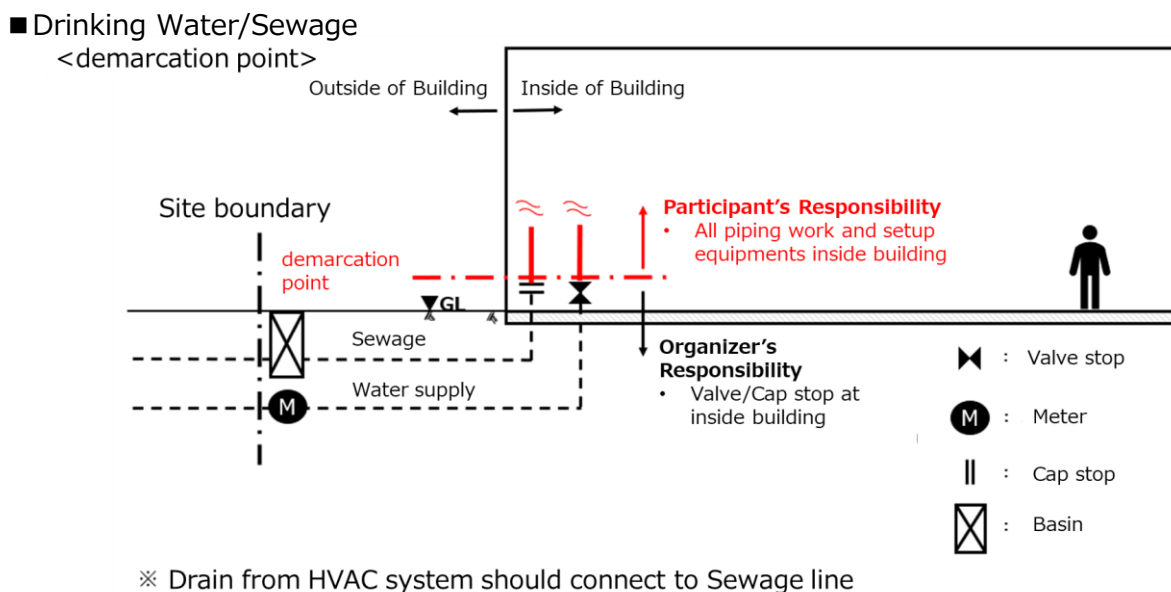

#### 4-2-2. Sewage (wastewater)

The Organiser will install sewage system which can connect the wastewater network to the building.

#### 4-2-3. Sewage (rain water drainage)

The Organiser will install a rain water drainage network system within the site, connecting the drainage facilities situated near the buildings and the passageways in the site to the rain water drainpipes.

#### 4-2-4. Electricity

The Organiser will provide lot-voltage distribution switchboards which connect the electricity supply network to Pavilions. The supplied electricity will be as follows.

- a. Electricity: low voltage (100 V, 200 V)
- b. Frequency: 60 Hz

Regarding the single-phase or three-phase power that can be used by the Participants in the pavilion where the Organiser supplies the low voltage electricity, the load can be divided within the range not exceeding the allocated capacity.

Construction work for electricity is to be carried in compliance with the Act on Electricity Business, technical standards for electric equipment, and other relevant Japanese laws and regulations.

Figure 4.2 Electricity demarcation point near on-site passageway boundary lines

#### ■ Electrical equipment

<demarcation point>

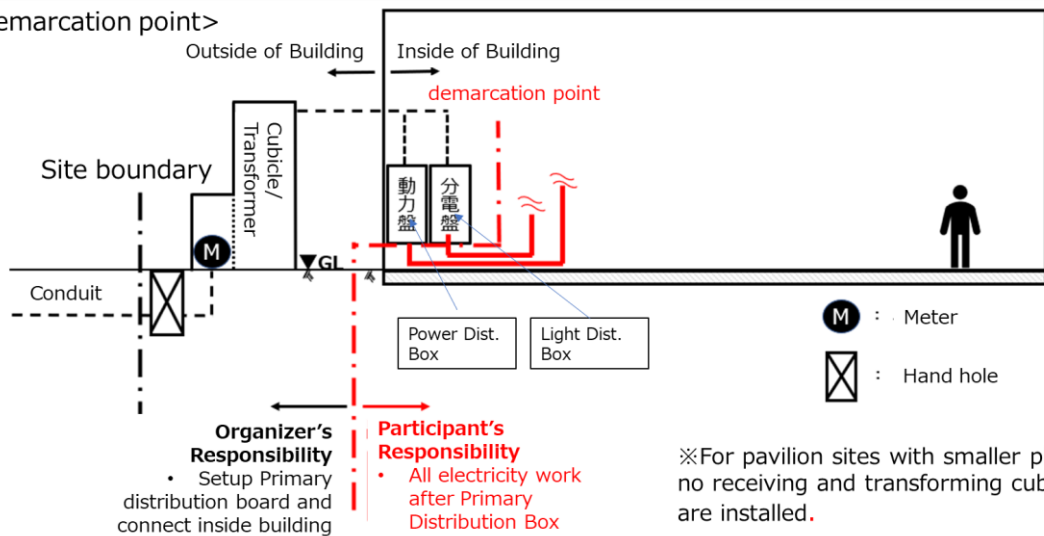

- C-061** Throughout the Expo period, the maximum amount of electricity that Participants use shall be within the power level that the Organiser indicates in drawings etc. If the Organiser requests Participants to report on maximum power levels used, the Participants shall do so promptly.
- C-062** Participants shall improve power factors so that the lagging power factor at the system connection point is 85% or higher. Participants shall also ensure that the power factors do not become leading power factors and submit a calculation document.
- C-063** In the following cases, Participants shall install necessary adjustment or protection apparatus.
- a. When the balance in load between each phase is markedly lacking due to the nature of the load
  - b. When the voltage or frequency markedly fluctuates due to the nature of the load
  - c. When the waveform is markedly distorted due to the nature of the load
  - d. When markedly high frequency or harmonic is generated
  - e. In other cases equivalent to a, b, c, or d

Participants shall submit a list of equipment and calculation document.

**C-064** When Participants install interconnected power generating equipment, they shall file applications to the Organiser before starting the installation work of the power generating equipment, using application forms for approvals of Utility service access. Participants are not permitted to cause reverse power flow to areas outside their buildings.

**C-065** Participants shall use equipment and materials that meet relevant Japanese standards such as Japanese Industrial Standards (JIS), standards of the Japanese Electrotechnical Committee (JEC), standards of the Japan Electric Manufacturers' Association (JEM), Japanese Cable Makers' Association Standard (JCS), and Japan Electric Association Code (JEAC) as well as provisions in the Act on Electrical Appliance and Material Safety. However, to promote global procurement of equipment and materials, Participants will be permitted to use other equipment and materials that meet IEC (International Electrotechnical Commission) specifications only if the specifications are deemed to be equivalent to or more stringent than Japanese specifications. When using such equipment, if the equipment or materials are not approved by technical standards for electric equipment, the Participants shall research how the equipment or materials differ from counterparts that meet Japanese standards and for prior approvals, submit by the time the equipment and materials are used in construction to the Organiser, documents indicating that the specifications are equivalent to or more stringent than Japanese specifications, and obtain the approval from the Organiser for use.

#### 4-2-5. Gas

The Organiser will not provide a gas supply network. If gas is necessary, Participants are to procure and fund gas by themselves. When using gas, LPG shall be used. The Organiser will provide a list of gas sales operators.

**C-066** If Participants use gas, they shall enter into agreements with gas sales operators. Participants shall report to the Organiser the name of the LPG sales operator. Participants shall have fire prevention supervisors develop fire prevention plans, execute fire preventive measures that comply with laws and regulations, and report the content to the Organiser.

Gas-related constructions shall be carried out in compliance with laws and regulations including the Act Concerning the Securing of Safety and the Optimisation of Transaction of Liquefied Petroleum Gas.

#### 4-2-6. Telecommunications

The Organiser shall install equipment storage boxes for the telecommunication infrastructure inside the buildings. Where Participants subscribe to cable services, the cable services shall be provided by telecommunication operators. Telecommunication-related rules can be obtained from the Organiser.

The Organiser and telecommunication operators shall be authorised to enter the Pavilions and pursue equipment installation or other telecommunication-related work even after the Pavilions are handed over.

**C-067** If Participants apply for cable services, they shall install specialised pipes from nearby the equipment storage boxes that the Organiser installs to the point where the Participants wish to terminate the cable services. Telecommunication operators are to perform the laying of cable lines.

**C-068** Participants shall install specialised pipes and lay cable lines from nearby the equipment storage boxes that the Organiser installs to the terminal point. Cable lines comply with 1000BASE-T (IEEE802.3ab) specifications and use UTP cables (unshielded twisted pair cable) that meet category 5e or higher specifications. Plugs shall be RJ-45, and pin assignments shall be in the form of TIA/EIA-568-B straight joints.

**C-069** If the length of cables from the equipment storage boxes to the terminal instalment point exceeds 100 m, Participants shall secure instalment environments that can accommodate additional equipment storage boxes so that all cable lines are within 100 m. The installation environment is defined below, and installed by the Organiser. Further, Participants shall install specialised pipes and lay cable lines between the equipment storage boxes and additional equipment storage boxes and between additional equipment storage boxes and terminal points to be connected to such boxes. However, these standards do not apply to cable services.

> Installation space: width 1,100 mm × height 1,000 mm × depth 300 mm (when doors opened: 1,000 mm)

> Installation method: attached to walls (using bolts)

> Power source: single-phase 100 V 20 A with ground wire, Form of power outlet: NEMA 5-15R

**C-070** Construction work for cable lines shall be performed while paying attention to effects that might be caused by electric equipment and preventing problems in bent areas of the cables. The Organiser may request Participants to resolve any telecommunication problems that arise from cable line equipment that the Participants prepare, and the Participants shall respond to such requests.

Figure 4.3 Example of construction categories in the telecommunication infrastructure

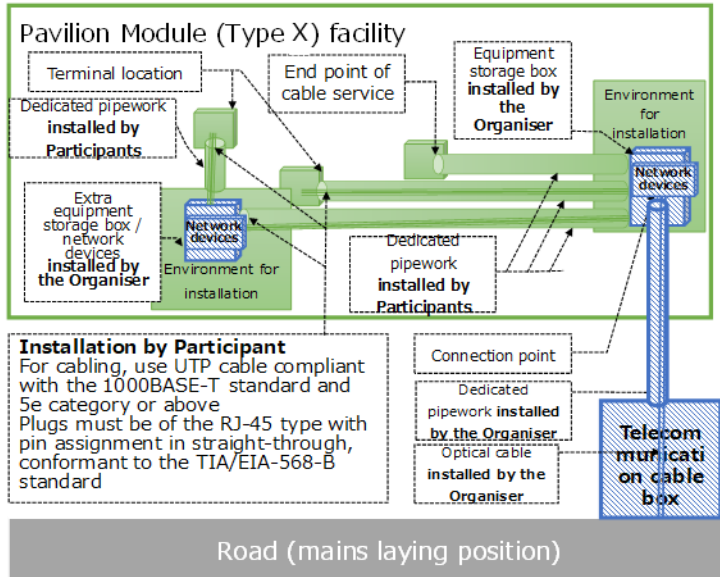

**[Participants]**

Installs **dedicated pipework for the cable service** from the vicinity of the equipment storage box to the end terminals \*Cabling to be implemented by a telecommunication operator

If the cable extends more than 100 m to reach the end terminals, **Participants secure spaces for installing extra equipment storage boxes** so that all cable sections are shorter than 100 m (installed by the Organiser)

Participants install **dedicated pipework and lay cables** from the equipment storage boxes to the extra equipment storage boxes and further from these boxes to the terminal devices to be connected to them.

**[Organiser]**

Installs equipment storage boxes (extra equipment storage boxes)

Infrastructure supply network as part of the Utility services includes **the implementation of the optical cables** up to equipment storage boxes via the telecommunication cable box and **IT infrastructure** (installation of network devices)

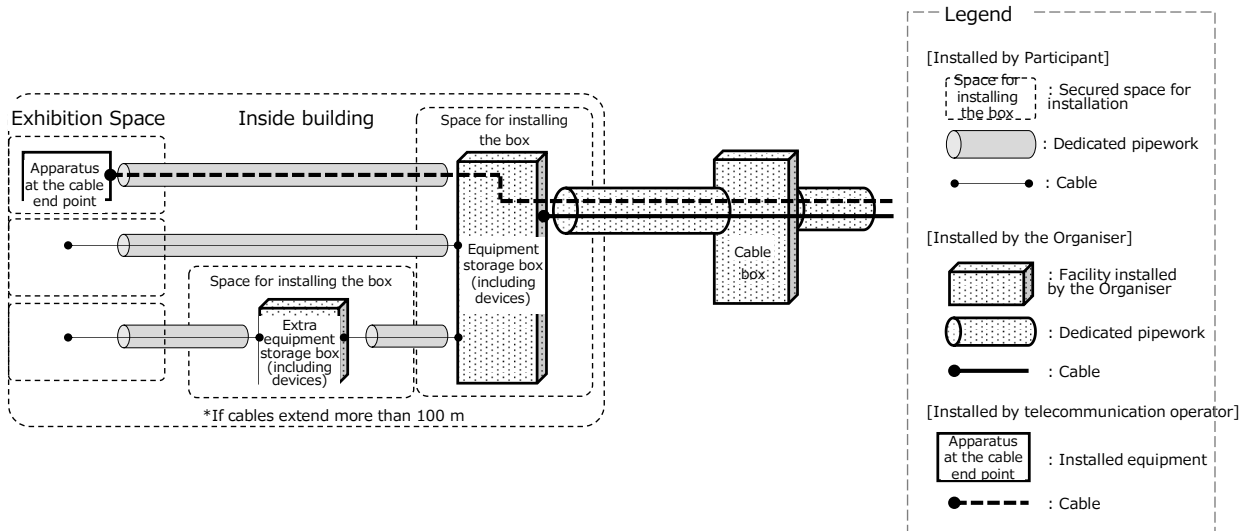

**4-2-7. Chilled Water**

The Organiser will install chilled water supply pipes for air conditioning which connects the chilled water supply network to the duct access chamber in Pavilions. The Organiser provides segment valves in a two-pipe system near the buildings, and the supply flow pressure by the segment valves is approximately 0.2 MPa, chilled water supply temperature is approximately 9°C, and return temperature is approximately 19°C.

Figure 4.4 Chilled water segment valves near on-site passageway boundary lines

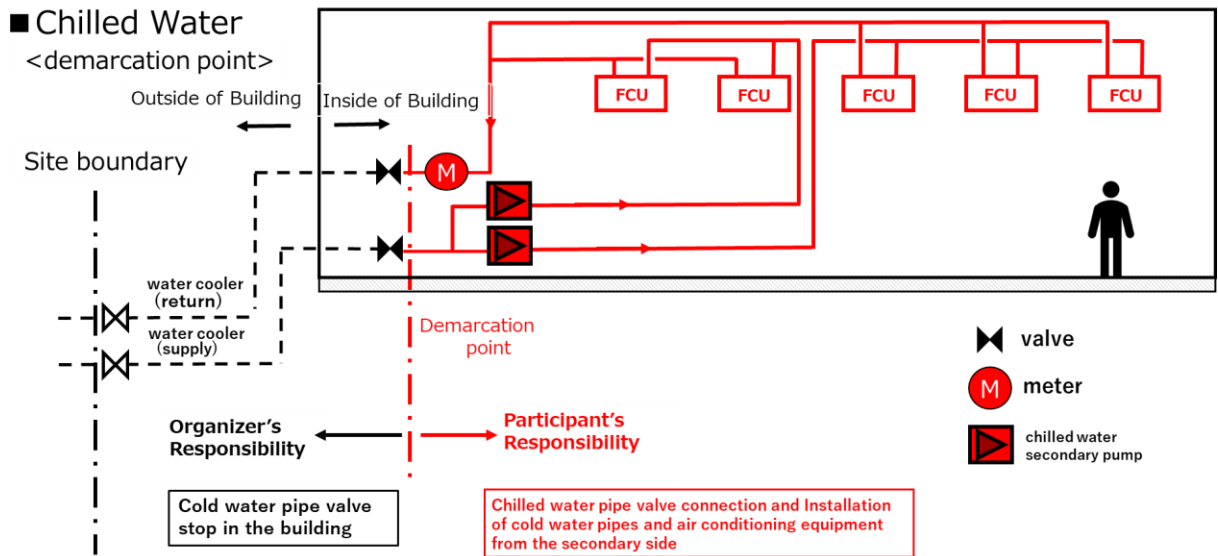

**C-071** Participants shall install air conditioning equipment that enables a 10°C or more difference in the temperature of supplied and returning chilled water throughout the period of the Expo. All air handling units, fan coil units, and other air conditioning units shall be proportionally controlled with two-way valves. This proportional control will have a temperature control proportional integral derivative (PID) loop for room temperature and a PID loop for the temperature of returning chilled water (return temperature) to secure the difference in temperatures. The two PID outputs (0-100%) by the selection of higher value of the two output will control two-way valves\*.

\*This control is a function generally implemented in recent direct digital controls (DDC). The following indicates referential model numbers of fan coil unit (FCU) controllers.

Infilex™ FC Fan Coil Unit Controller, manufactured by Azbil Corporation (model number: WY5205W3000, SC-bus communication / standalone use, power AC100-240V, proportional control with return temperature control)

Figure 4.5 Controls in air conditioning units

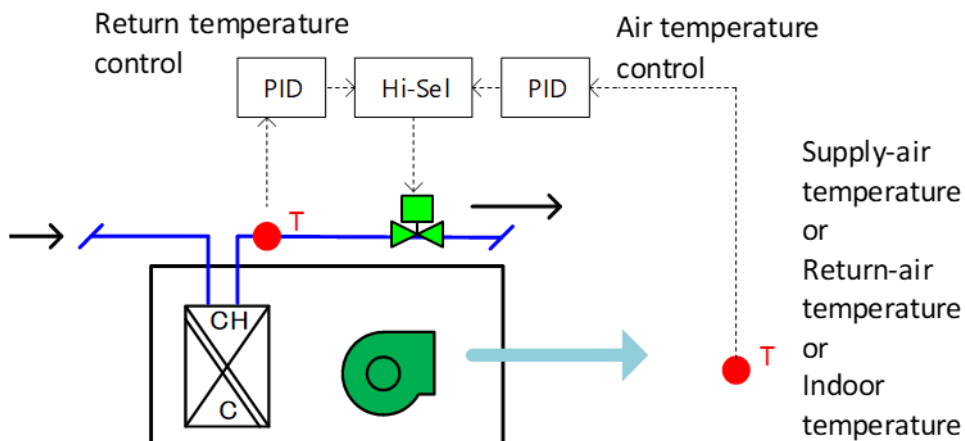

**C-072** Participants shall install within buildings chilled water secondary pumps that circulate chilled water. The lifting height of chilled water secondary pumps shall be secured between the chilled water supply pipes at the on-site passageway boundary lines to returning chilled water pipes at the on-site passageway boundary lines

**C-073** For secondary chilled water pumps, Participants shall install inverters in all constituent units, reduce conveyance power with estimated differential pressure controls and such, and implement inverter variable flow controls that can secure difference in supplied chilled water. Additionally, the lower limit to frequency in inverters shall be adjusted to 20% (12 Hz) of electric motor rated frequency (60 Hz). Since the lower limit to frequency will be 20% or less, bypass pipes and bypass valves to prevent elevated temperatures in pumps when the load side is blocked are to be the minimum necessary small diameter and not significantly larger than that (because excessive flow in bypasses cause a reduction in secondary temperature difference).

Figure 4.6 Control of secondary pumps

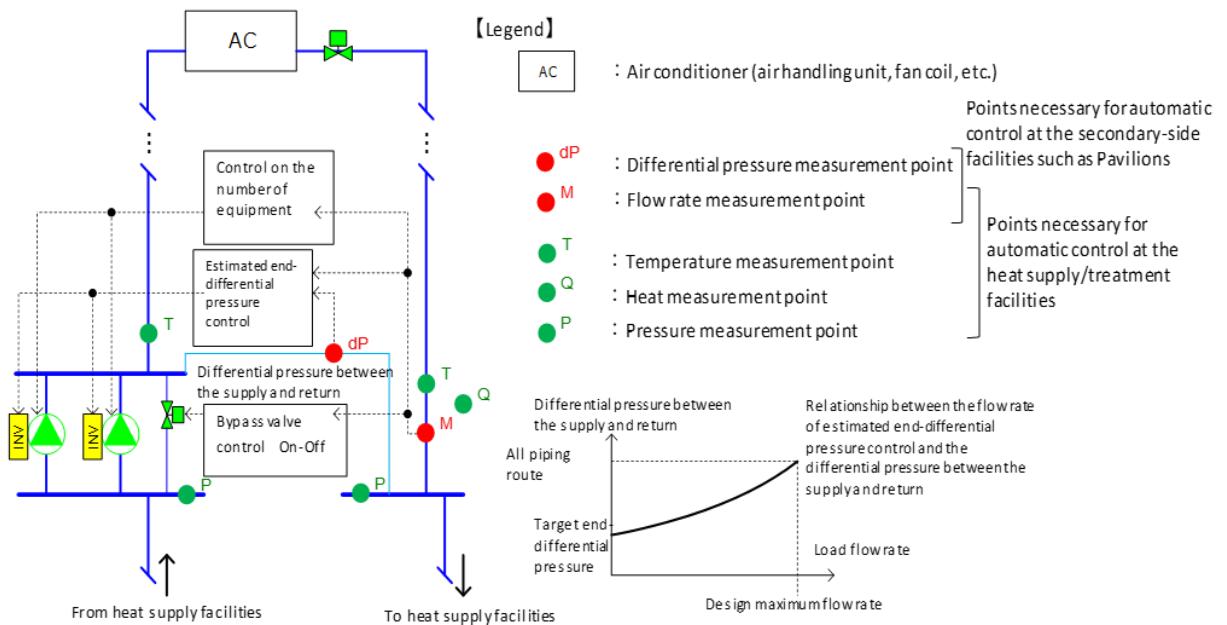

**C-074** If the Organiser requests Participants to submit lists of equipment indicating specifications of air conditioning equipment, instrumentation flow charts, checklist for mandatory design requirements in Table 4.1, and specification tables for selecting chilled water secondary pumps in Table 4.2, the Participants shall do so promptly.

Table 4.1 Sample of how to fill in the checklist for mandatory design requirements

Item	Requirement	Check
Inverter instalment	All units have inverters	○
Number of pumps	Divided into multiple units and implements control for the number of units according to load flow.	○
Control requirements	Variable control for differential pressure between supply and return 1) Implements estimated differential pressure controls 2) Minimum rotation rate (rate in comparison to commercial frequency) of the inverter's main body at 20% or less	○ 12 Hz (20%)
	Bypass valve control to prevent heating of pumps 1) Uses on-off controls according to load flow 2) Bypass pipe diameters that correspond with a flow sufficient to suppress the elevation of temperature due to heat caused by each pump operating at minimum frequency *The bypass flow is to be roughly 10% of each pump's rated flow.	○ ○
Requirements of secondary air conditioning systems	All air conditioning units implement two-way valve PI controls	○
	Controls for returning temperatures (Figure 4.4) are implemented as a measure to prevent excessive flow (water volume control) in air conditioning units	○ ○

Table 4.2 Example of how to fill in specification tables for selecting chilled water secondary pumps

Item	Design value	Unit	Remarks
Maximum load power on design	16011	MJ/h	Maximum load power on design derived from thermal load calculations.
Difference in load temperature on design	10.0	°C	Difference in coil temperature in air conditioning units.
Maximum flow on design	151.4	m <sup>3</sup> /h	Value when maximum load power on design is divided by difference in load temperature on design.
Total resistance in pipe pathways on design	147	kPa	Total resistance in pipe pathways when maximum flow on design flows. Net resistance value.
Target value for differential pressure	40	kPa	Total rated differential pressure of coils and control valves in terminal air conditioning units.
Selected pumps operating-point flow	66.0	m <sup>3</sup> /h	Flow of selected pumps at operating points. As a general rule, value when maximum flow on design is divided by the number of pumps.
Selected pumps operating-point lifting height	225.4	kPa	Lifting height of selected pumps at operating points. Lifting height at operating points of pumps ultimately selected in light of the estimated percentage of allowance in total resistance in pipe pathways on design.
Selected pumps electric motor output	7.5	kW	Rated output of electric motors in selected pumps.
Number of units constituting secondary pumps	3	units	
Inverter minimum frequency	15	Hz	Minimum frequency at 30% or less than commercial frequency.
Inverter maximum frequency	60	Hz	Maximum frequency decided based on trial operation and subsequent adjustments.
Flow in opened bypass valves	6.6	m <sup>3</sup> /h	Roughly 10% of each pump's rated flow



**C-075** For chilled water heat management and monitoring and control at the heat supply processing facility, Participants shall connect the five measuring points for load heat, load flow, temperature of supplied and returning chilled water, and differential pressure of the supplied and returning chilled water to the central monitoring system of the heat supply processing facility. The Organiser will provide the following equipment in May 2024 as of schedule.

- 1) Calorimeter
- 2) Signal input unit to feed signals to the central monitoring system in the heat supply facility equipment
- 3) Measurement sensors that are unnecessary for air conditioning control in Pavilions (sensors that the heat supply facility side requires)
  - > Pipe differential temperature sensors for supplied and returning chilled water (Pt100Ω)
  - > Pressure transmitters for pressure measurement at headers of supplied primary and returning

chilled water (4-20 mA)

> Signal amplifiers for load flow and differential pressure between supply and return (one for air conditioning control within buildings and another for monitoring points of the heat supply processing facility's central monitoring system)

Participants are to install the above provided items, incorporate them on panels, and perform any necessary pipe and cable constructions. The following diagram shows construction categories.

Figure 4.7 Overview of constructions to be performed on the part of Pavilions  
(Construction for all items indicated with black lines and fonts are to be performed on the part of the Pavilions, highlighted items will be provided)

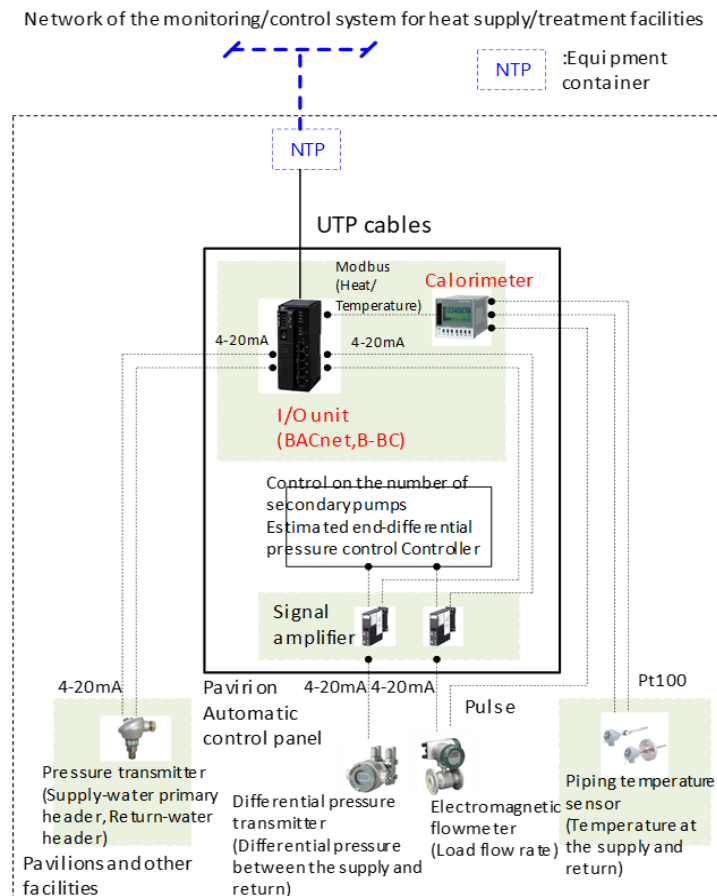

**C-076** Specifications of measurement devices, flow meters and differential pressure transmitters, that Participants install are to comply with the following.

- 1) Flow meter guideline
  - > Use magnetic flow meters.
  - > As a general rule, install them horizontally to the ground, and ensure a 5D and 2D straight pipe length for the front flow and back flow sides.
  - > As a general rule, use magnetic flow meters of the same diameter size as pipes.
- 2) Differential pressure transmitter guidelines
  - > Keep the range at 0-400 kPa or less.

**C-077** After the valves, pipes shall be inclined toward buildings, and air shall be released.

**G-029** To improve the efficiency of refrigeration machines of the chilled water supply network for air conditioning that the Organiser installs and to reduce greenhouse gas emissions by reducing chilled water conveyance power, it is preferable if the difference in supplied and returning chilled water is 13°C or more (returning chilled water of 22°C or higher).

**G-030** It is preferable if fresh-air inlet controls based on CO<sub>2</sub> concentration levels (inside rooms or returning air) that can both reduce air conditioning load and secure an appropriate amount of ventilation are implemented.

**G-031** To reduce conveyance power and secure difference in the temperature of supplied chilled water, it is preferable if the minimum frequency of secondary chilled water pump inverters is adjusted to 12 Hz or below.

**G-032** It is preferable if the pipes use plastic materials, such as in polythene water supply pipes or metal reinforced polythene pipes.

The following are specific examples of recommended air conditioning systems.

1) Single-duct method in air conditioning units

- > A method that applies pre-cooling coils in air conditioning units to secure difference in supplied chilled water. Applies medium temperature chilled water pumps and circulates medium temperature chilled water so that the returning chilled water is at 22°C.
- > When secondary chilled water pumps malfunction, the medium temperature chilled water pumps can be used as backups of secondary chilled water pumps by switching valves.

Figure 4.8 Overview of the single-duct method system in air conditioning units

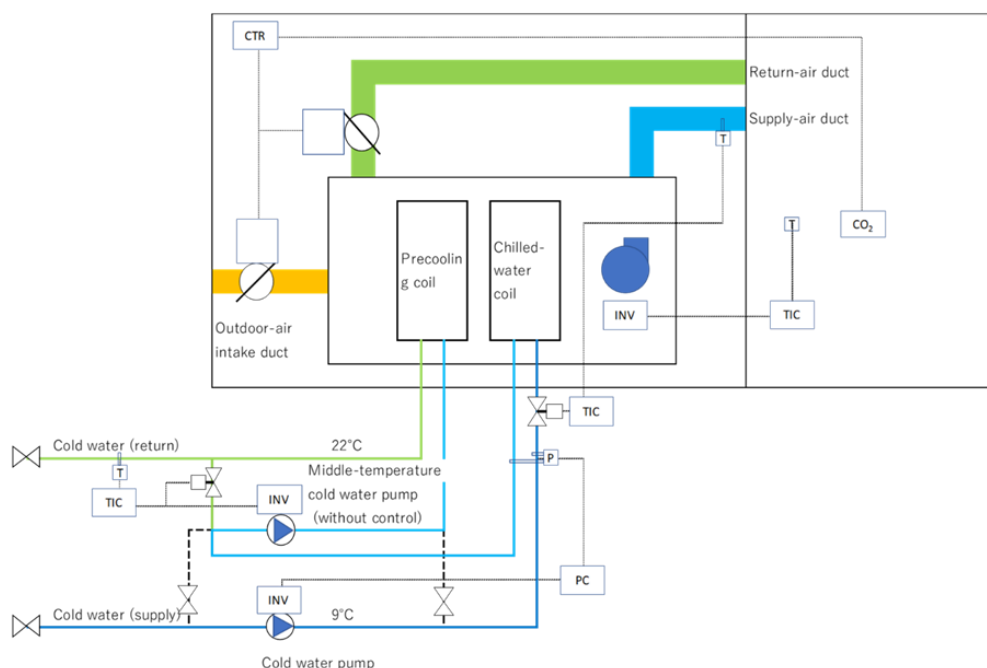

- > Control for chilled water pump inverters: inverter control of chilled water pump variable flow according to differential pressure

- > Control for air supply temperature in air conditioning units: control of chilled water coil two-way valve according to air supply temperature in air conditioning units
- > Control for variable air volume in air conditioning units: fan inverter control in air conditioning units according to room temperature
- > CO<sub>2</sub> concentration level based control for fresh-air inlet volume: proportional control on fresh-air inlet metal ducts and return-air metal ducts according to room CO<sub>2</sub> concentration levels
- > Control for returning chilled water temperature: two-way valve control on circulation of returning chilled water and inverter control on medium temperature chilled water so that the set temperature of returning chilled water is 22°C

## 2) Fan coil unit method

Fan coil units for two-way valve chilled water control for dehumidification and cooling and difference in supplied chilled water are enabled.

Sensible heat processing fan coil units are installed. Difference in supplied chilled water is enabled by circulating medium temperature chilled water in sensible heat fan coil units.

Figure 4.9 Overview of fan coil unit method system

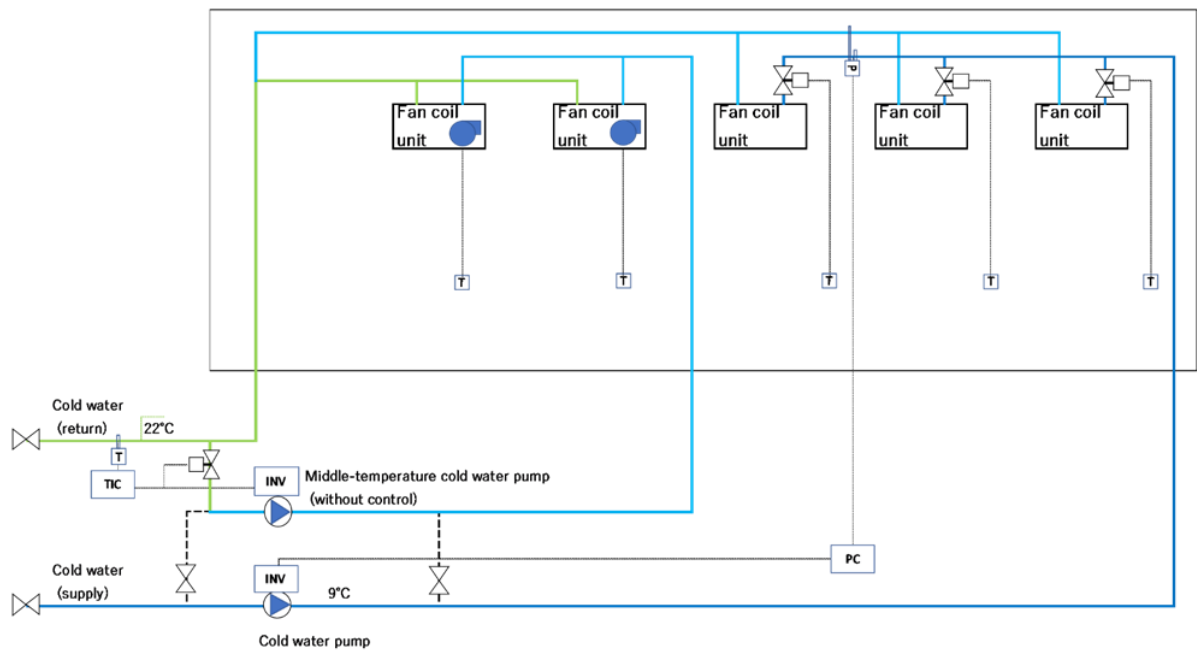

The performance level of sensible heat processing fan coil units (15°C chilled water) is 45% to 60% that of 7°C chilled water fan coil units. The following is referential information from manufacturers.

Table 4.3 Example of chilled water fan coil unit performance

Cooling capacity										
Inlet air temperature 27.0°CDB, 19.5°CWB										
Model number	Water volume range		Inlet temperature 15°C			Water volume range		Inlet temperature 7°C		
			Sensible heat	Total heat	Temperature difference			Sensible heat	Total heat	Temperature difference
	l/min	kW	kW	°C	l/min	kW	kW	°C		
FWJC 12EH	Minimum	8.0	4.65	4.65	8.3	Minimum	8.0	7.76	7.76	13.9
	∩	10.6	5.15	5.15	7.0	∩	10.6	7.94	9.94	10.0
	Maximum	17.5	5.86	5.86	4.8	Maximum	17.5	8.75	11.35	9.3
FWBC 40FH6	Minimum	12.0	6.32	6.37	7.6	Minimum	12.0	9.05	11.24	13.4
	∩	13.7	6.64	6.69	7.0	∩	13.7	10.40	14.75	10.0
	Maximum	23.0	7.49	7.55	4.7	Maximum	23.0	10.59	15.23	9.5

\*Calculated on the assumption that a two-pipe system and coils for large temperature difference (10 ° C) are used.

Cooling capacity										
Inlet air temperature 26.0°CDB, 18.7°CWB										
Model number	Water volume range		Inlet temperature 15°C			Water volume range		Inlet temperature 7°C		
			Sensible heat	Total heat	Temperature difference			Sensible heat	Total heat	Temperature difference
	l/min	kW	kW	°C	l/min	kW	kW	°C		
FWJC 12EH	Minimum	8.0	4.27	4.27	7.7	Minimum	8.0	7.35	7.35	13.2
	∩	9.2	4.49	4.49	7.0	∩	13.0	7.55	9.03	10.0
	Maximum	17.5	5.37	5.37	4.4	Maximum	17.5	8.24	10.38	8.5
FWBC 40FH6	Minimum	12.0	5.81	5.85	7.0	Minimum	12.0	8.77	10.54	12.6
	∩	12.1	5.83	5.87	7.0	∩	19.1	9.84	13.28	10.0
	Maximum	23.0	6.88	6.93	4.3	Maximum	23.0	10.21	14.20	8.8

\*Calculated on the assumption that a two-pipe system and coils for large temperature difference (10 ° C) are used.

- > Control for chilled water pump inverters: chilled water pump inverter control according to differential pressure
  - > Control for fan coil units: proportional control of fan coil unit two-way valves according to room temperature
  - > Control for sensible heat processing fan coil units: fan coil unit control according to room temperature
  - > Control for returning chilled water temperature: two-way valve control on circulation of returning chilled water and inverter control on medium temperature chilled water so that the set temperature of returning chilled water is 22°C
- 3) Method combining air conditioning units and fan coil units
- Air conditioning units use a method almost exactly the same as that described in the above (1) Single-duct method in air conditioning units. Air conditioning units operate on a constant air volume system, and fan coil units control room temperature. It can accommodate any small rooms, if any.

Figure 4.10 Overview of method system combining air conditioning and fan coil units

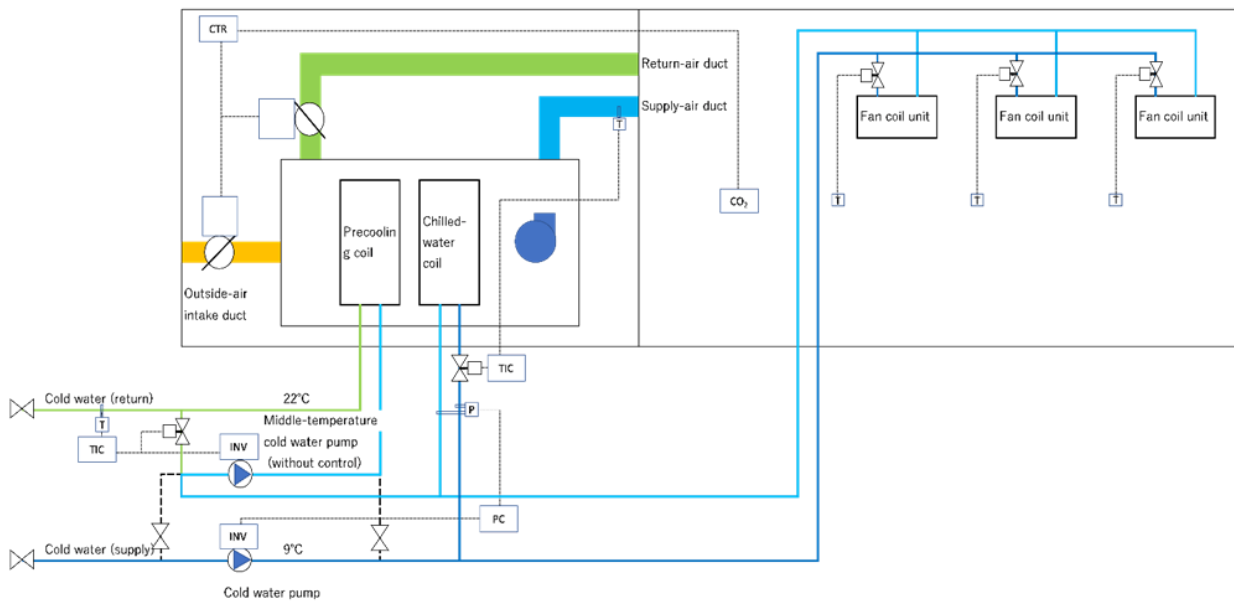

- > Control for chilled water pump inverters: inverter control of chilled water pump variable flow according to differential pressure
- > Control for air supply temperature in air conditioning units: chilled water coil two-way valve control according to air supply temperature in air conditioning units
- > Control room temperature: proportional control of fan coil unit two-way valves according to room temperature
- > CO<sub>2</sub> concentration level based control for fresh-air inlet volume: proportional control on fresh-air inlet metal ducts and return-air metal ducts according to room CO<sub>2</sub> concentration levels
- > Control for returning chilled water temperature: two-way valve control on circulation of returning chilled water and inverter control on medium temperature chilled water so that the set temperature of returning chilled water is 22°C

4) Method combining fresh-air processing air conditioning units and metal reinforced polythene pipe radiation cooling

The difference in supplied chilled water is secured with the pre-cooling coil of air conditioning units and metal reinforced polythene pipe radiation cooling within rooms, using 15°C medium temperature chilled water. Fresh-air processing air conditioning units are used for dehumidification, and metal reinforced polythene pipe radiation cooling is used for sensible heat processing within rooms.

Figure 4.11 Overview of method system combining fresh-air processing air conditioning and metal reinforced polythene pipe radiation cooling

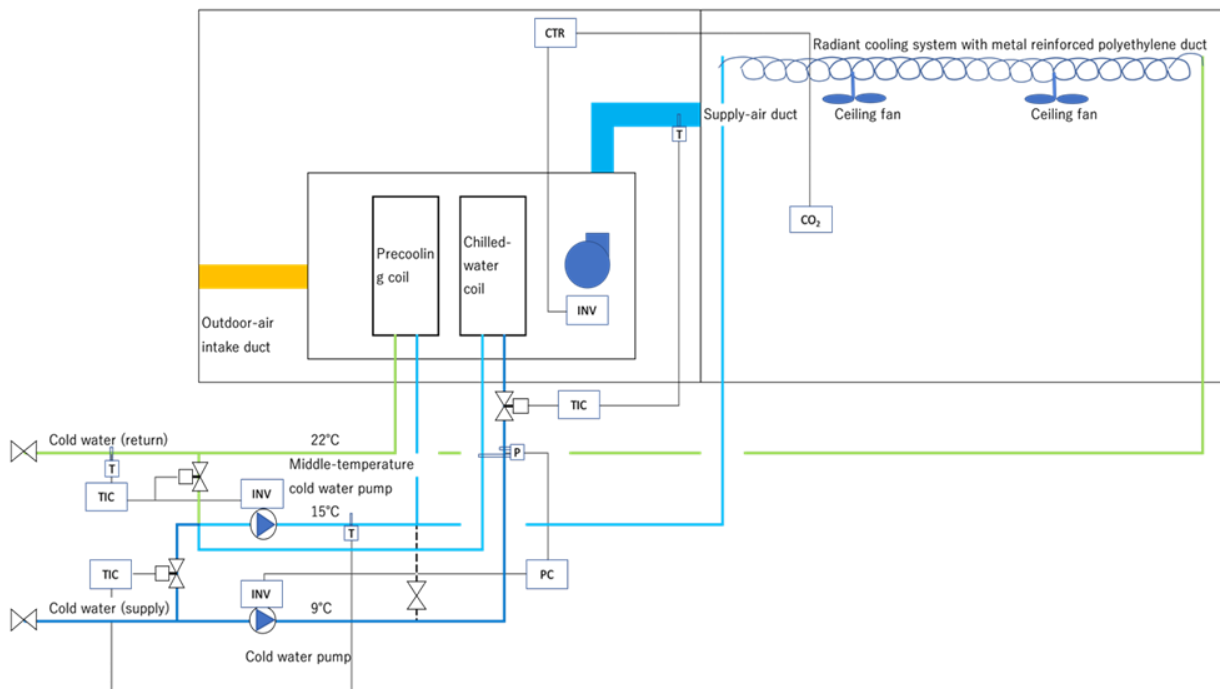

- > Control for chilled water pump inverters: inverter control of chilled water pump variable flow according to differential pressure
  - > Control for air supply temperature in air conditioning units: chilled water coil two-way valve control according to air supply temperature in air conditioning units
  - > Control room temperature: proportional control of fan coil unit two-way valves according to room temperature
  - > CO<sub>2</sub> concentration level based control for fresh-air inlet volume: inverter control of fresh-air processing air conditioning unit fans according to room CO<sub>2</sub> concentration levels
  - > Control for medium-temperature chilled water temperature: control of chilled water two-way valves so that the temperature of supplied medium temperature chilled water is 15°C
  - > Control for central water temperature: two-way valve control on circulation of returning chilled water and inverter control on medium temperature chilled water so that the set temperature of returning chilled water is 22°C
- 5) Method combining fresh-air processing air conditioning units and sensible heat processing fan coil units
- The difference in supplied chilled water is secured by the pre-cooling coil in air conditioning units and sensible heat processing fan coil units, using 15°C medium temperature chilled water. Fresh-air processing air conditioning units are used for dehumidification, and sensible heat processing fan coil units are used for sensible heat processing within rooms.

Figure 4.12 Overview of method system combining fresh-air processing air conditioning and sensible heat processing fan coil units

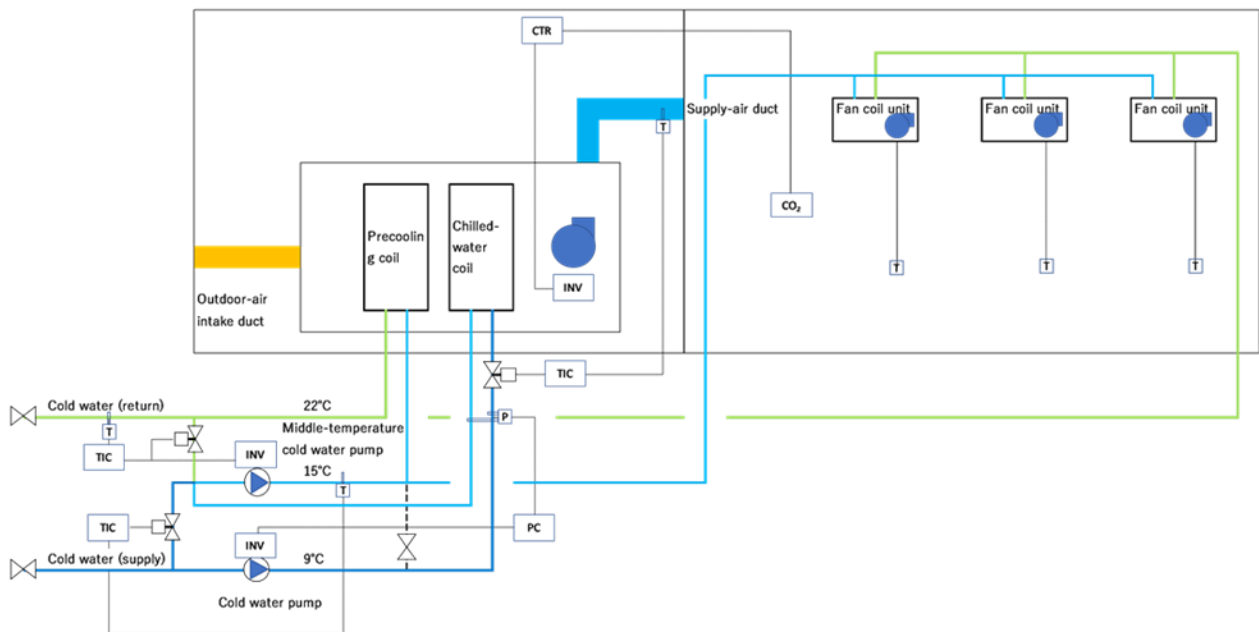

- > Control for chilled water pump inverters: inverter control of chilled water pump variable flow according to differential pressure
- > Control for air supply temperature in air conditioning units: chilled water coil two-way valve control according to air supply temperature in air conditioning units
- > Control room temperature: proportional control of fan coil unit two-way valves according to room temperature
- > CO<sub>2</sub> concentration level based control for fresh-air inlet volume: inverter control of fresh-air processing air conditioning unit fans according to room CO<sub>2</sub> concentration levels
- > Control for central chilled water temperature: control of chilled water two-way valves so that the temperature of supplied medium temperature chilled water is 15°C
- > Control for returning chilled water temperature: two-way valve control on circulation of returning chilled water and inverter control on medium temperature chilled water so that the set temperature of returning chilled water is 22°C

In (4) and (5) above, since the chilled water pipes within rooms are 15°C to 22°C, if fresh-air processing air conditioning units are used for dehumidification, insulation work will be unnecessary, and thus, it is assumed that construction costs will be reduced.

### 4-3. Documents to be Submitted

The following are documents concerning this Chapter that the Organiser requires Participants to submit. The documents are to be submitted to the Organiser via the online portal for the Official Participants. Designated formats for documents to be submitted will be made available on the online portal for the Official Participants.

Names of documents to be submitted:

- > Application form for the approval of access to Utility services (4-2)
- > [If necessary] Report on maximum power value (4-2-4)
- > [If necessary] Report on LPG sales operators, report on fire prevention supervisor's fire prevention plan and fire preventive measures (4-2-5)
- > [If necessary] Equipment list, instrumentation flow chart, and checklist for mandatory design requirements, specification table for chilled water secondary pump selection (4-2-7)

Table 4.4 Equipment work classification (relevant to Chapters 3 and 4)

Name of equipment		Work to be carried out by the Organiser	Work to be carried out by Participants
Electricity	Supply lead-in cables and electricity receiving equipment (Low-voltage-supplied Pavilions)	<ul style="list-style-type: none"> <li>- Voltage: 200 V, Frequency: 60 Hz Power sources for Participants</li> <li>- Three-phase: installation of power boards The power board receives electric power for the low-voltage 3-phase 4-wire distribution system. Installation of breakers for power boards for exhibition. Installation of an electricity meter on the primary side of the main breaker.</li> <li>- Single-phase: installation of distribution Installation of breakers for distribution switchboards for exhibition. Installation of branch circuits required for disaster prevention equipment and function preservation equipment. Installation of an electricity meter on the primary side of the main breaker.</li> <li>- Installation of main line connections from the power boards to the distribution switchboards: supplies electric power received at the terminal inside the power board to the distribution switchboards in the single-phase 3-wire distribution system</li> </ul>	<ul style="list-style-type: none"> <li>3-phase: installation of power boards (branch circuits) for exhibition</li> <li>Single-phase: installation of distribution switchboards (branch circuits) for exhibition</li> </ul>
	Electricity lead-in cables - Electricity receiving equipment (High-voltage-supplied Pavilions)	<ul style="list-style-type: none"> <li>- Voltage: 6.6 kV, Frequency: 60 Hz [High-voltage receiving equipment] Installation of cubicles for receiving/transforming electricity outside Pavilions. Installation of low-voltage main cable from the cubicles to the power boards and distribution switchboards. Electricity meters installed in cubicles.</li> <li>[Low-voltage power source equipment] Power sources for Participants (* Collective building: Exhibition Space and the administrative areas)</li> <li>- Three-phase: installation of power boards Installation of breakers for power boards for exhibition.</li> <li>- Single-phase: installation of distribution Installation of breakers for distribution switchboards for exhibition. Installation of branch circuits required for disaster prevention equipment and function preservation equipment.</li> </ul>	<ul style="list-style-type: none"> <li>3-phase: installation of power boards (branch circuits)</li> <li>Single-phase: installation of distribution switchboards (branch circuits) for exhibition</li> </ul>
	Electrical sockets	<ul style="list-style-type: none"> <li>- Not installed (* Collective building: installed in the administrative rooms)</li> </ul>	<ul style="list-style-type: none"> <li>- Installation of electrical sockets and other power-source-related equipment as well as piping and wiring (* Collective building: additions and changes)</li> </ul>
	Lighting	<ul style="list-style-type: none"> <li>- Not installed (* Collective building: necessary lighting is installed in the administrative rooms while basic lighting and spotlights are installed in the exhibition areas)</li> </ul>	<ul style="list-style-type: none"> <li>- Installation of lighting equipment, piping, and wiring (* Collective building: additions and changes)</li> </ul>
	Emergency lights Emergency exit lights	<ul style="list-style-type: none"> <li>Installed according to standard arrangements</li> </ul>	<ul style="list-style-type: none"> <li>- Additions/changes due to installation of partition walls and other features</li> </ul>
	Announcement equipment	<ul style="list-style-type: none"> <li>- Installation of main amplifier equipment for emergency/staff announcement</li> <li>- Installation of speakers according to standard arrangements</li> </ul>	<ul style="list-style-type: none"> <li>- Additions/changes due to installation of partition walls and other features</li> </ul>



Name of equipment		Work to be carried out by the Organiser	Work to be carried out by Participants
Electricity	Automated fire alarm equipment	<ul style="list-style-type: none"> <li>- Installation of Pavilion a main receiver</li> <li>- Arrangement of detectors according to standard arrangements. They are connected to the automated fire alarm mission-critical system in the central control facility</li> <li>- Installation of ductwork for installing infrastructure up to the receivers</li> </ul>	- Additions/changes due to installation of partition walls and other features
	Light-based Alarm Equipment	- Not installed (* Collective building: installed inside WC booths and lavatories)	- Participants to install as necessary
Ventilation		-Installed in standard arrangement	-Additional changes due to installation of partition walls, etc.
Water		<ul style="list-style-type: none"> <li>- Between the valves/meters installed at passageway boundary lines to the connection points in the valve stoppers on the floor in the building</li> <li>- Water pressure: 0.3 MPa</li> </ul>	- Installation beyond the point stated in the left
Sewage (wastewater)		- Between the drain boxes installed at on-site passageway boundary lines to the connection points in the cap stoppers on the floor in the building	- Installation beyond the point stated in the left
Telecommunication equipment		<ul style="list-style-type: none"> <li>- Lead-in cables on the secondary side of the handholes at on-site passageway boundary lines</li> <li>- One unit of IP telephone and piping/wiring connections to equipment storage boxes</li> <li>(* Collective building: installation of 1 telecommunication connection point in each exhibition booth)</li> </ul>	- Installation of HUB, piping and wiring, and equipment for connecting branch circuits
Chilled water		<ul style="list-style-type: none"> <li>- Supply temperature: 9°C, return temperature: 19°C</li> <li>- Between the valves installed at passageway boundary lines to the connection points in the valve stoppers on the floor in the building</li> </ul>	- Air-conditioning systems beyond the point stated in the left (* Collective building: additions and changes)
Gas		- Not installed	- Participants install an LPG supply system at their own cost if they need it.
Fire fighting equipment		<ul style="list-style-type: none"> <li>- Fire extinguishers: installed according to standard arrangements</li> <li>- Indoor fire hydrants: outdoor fire hydrants will substitute them</li> <li>- Sprinklers: not installed (not required)</li> <li>- Outdoor fire hydrants: installation between on-site passageway boundary lines and fire hydrants</li> <li>- Smoke extraction equipment: installation not required as windows are included in designs (natural smoke evacuation)</li> </ul>	<ul style="list-style-type: none"> <li>- Fire extinguishers: installation according to locational alterations/additional placements</li> <li>- Sprinklers: Installation is required if the floor area is 1,000 m<sup>2</sup> or more and if there are no windows.</li> </ul>
Security	Security cameras	- Not installed (* Collective building: installed according to standard arrangements)	- To be installed by Participants (* Collective building: additions/changes due to installation of partition walls and other features)
	Mechanical security equipment	- Not installed (* Collective building: installation of space sensors, piping and wiring, and security monitoring control panel according to standard arrangements)	- To be installed by Participants as necessary (* Collective building: additions/changes due to installation of partition walls and other features)

## 5. Rules and Management of Interior/Exterior Work etc. Within Expo Site

This Chapter defines rules of Interior/Exterior Work etc. within the Expo Site and requirements and recommendations for its management with the aim of supporting Participants during the implementation of the interior and exterior decoration work for their Pavilion Modules (Type X).

The Organiser established the key rules of Interior/Exterior Work etc. and required work management within the Expo Site in this Chapter in order to enable Participants to implement interior/exterior decorations etc. of their Pavilions in the way that is consistent with the construction plan for the entire Expo Site. Participants shall also comply with other rules of construction work that are separately established by the Organiser outside of this Guidelines document.

### 5-1. Construction Plan for Entire Expo Site

The Organiser will establish a construction plan for the entire Expo Site, including required management system for the construction work of the entire Site, temporary work-related facilities that may be used by all of the contractors, and traffic control system for construction/commuter vehicles. Participants and their contractors shall comply with the construction plan for the entire Expo Site in executing their Interior/Exterior Work etc. of Pavilions.

#### 5-1-1. Communication and Coordination Council

As construction/infrastructure work for multiple facilities, including Pavilions, are carried out within the Expo Site at the same time, it is important to coordinate such work conducted by various contractors, monitor and control the progress of each work, control the traffic of construction/commuter vehicles, and ensure compliance with the rules of construction work, etc. In addition, other projects, including that for IR, are ongoing in Yumeshima Island, and thus coordination with parties involved in Yumeshima-related work is necessary. In order to ensure smooth coordination among contractors, including those who are involved in the non-Expo projects in Yumeshima, the Organiser will establish the Communication and Coordination Council, that is led by the Organiser-appointed General Contractor (construction company). The following are key features of the Communication and Coordination Council, etc.

- The Organiser shall establish two types of Communication and Coordination Councils: the Expo Site Communication and Coordination Council, which is responsible for ensuring compliance with the rules of construction work within the Expo Site and facilitating coordination for the work on the Site; and sectional Communication and Coordination Councils, which are responsible for facilitating coordination for the work in the Organiser-designated sections within the Site (Hereinafter the "Communication and Coordination Council," for both the Expo Site Communication and Coordination Council and the sectional Communication and Coordination Councils.).

- The Communication and Coordination Council is, as the Organiser-appointed General Administrator, expected to give the Expo Site (sectional) General Contractors appointed by the Organiser instructions and work with them through reporting, communication, and coordination as necessary.

- The Communication and Coordination Council consists of the Organiser, General Contractors, Participants and their contractors, and other contractors that perform the construction work of facilities and infrastructure that the Organiser takes responsibility to prepare.

- The Organiser and the General Contractors, through the Communication and Coordination Council, have responsibility and authority to collect the opinions of contractors concerning what should be coordinated to perform the construction work and coordinate these contractors in line with this Guidelines document and the Organiser-established and approved rules of construction work discussed later.

- Each contractor shall report what should be coordinated to perform the construction work to the General Contractor in meetings, etc. held by the Communication and Coordination Council and the results of the coordination will be communicated to Participants and their contractors.

- The rules of the construction work, which is established by the Organiser outside of this Guidelines document, are communicated via the Communication and Coordination Council as well.

Figure 5.1 Schematic Diagram of Communication and Coordination Council

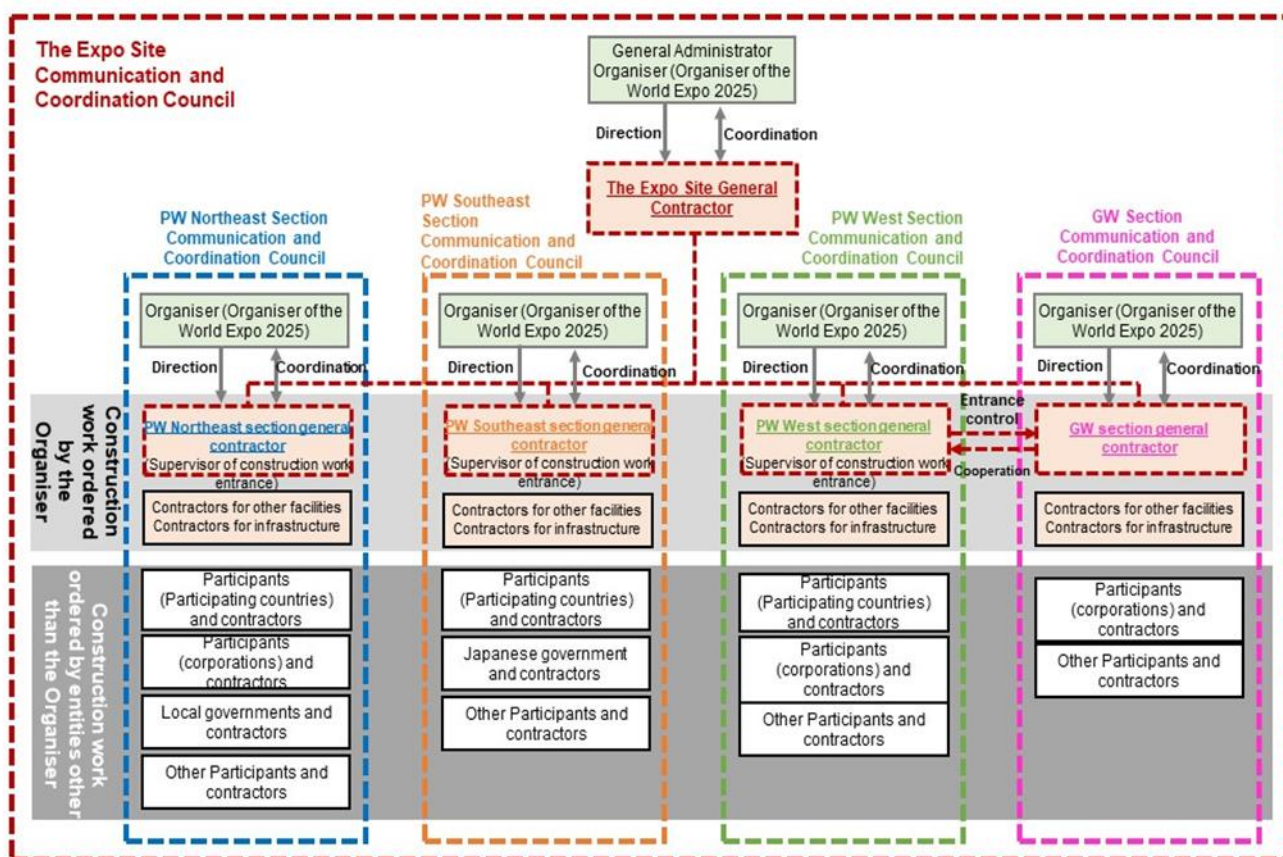

**C-078** Participants and their contractors shall participate in the Communication and Coordination Council of the section their Exhibition Spaces belong to. Participants shall submit a notification to participate in the relevant Communication and Coordination Council that confirms their participation therein (Please refer to Chapter 10). Participants shall offer cooperation to ensure the smooth site development in compliance with the rules established by the Organiser and according to the instructions of the General Contractor. In addition, Participants or their contractors shall attend the meetings the Organiser specifies. In addition to the construction rules in these guidelines, the Participants and their contractors shall also comply with the construction rules separately established by the Organiser. The construction rules are subject to change depending on changes in the construction conditions at the venue.

**C-079** Participants or their contractors shall, in compliance with the rules established by the Organiser, report to the General Contractors and follow the instructions of the Organiser and the General Contractors for the following items that require coordination with other Participants:

- Process and schedule of construction work
- Number of construction vehicles and their entry/exit timing by route to the Site
- Number of commuter vehicles and their entry/exit timing by route to the Site
- Plan describing the use of construction machine such as cranes in construction work
- Plan describing work that uses a space outside of their Exhibition Spaces

### 5-1-2. Shared Temporary Construction Facilities Within the Site

The Organiser will establish shared temporary construction facilities that any Participants and their contractor may use within the Site. The following are shared temporary construction facilities:

- Temporary enclosure on the periphery of the Site
- Passageway for construction within the Site
- Entrance gate (entry/exit control)
- Security guard at the entrance gate (entry/exit control)
- Construction vehicle management equipment
- Tire washing equipment (at each entrance gate)
- Temporary toilet facilities
- Work-support yards (construction vehicle standby spaces, meeting rooms and other communal spaces, etc.)

\* Temporary enclosures, gates, work-support yards, and the like may be repositioned as the work progress.

Figure 5.2 Draft Installation Plan for Temporary Construction Facilities in the Site

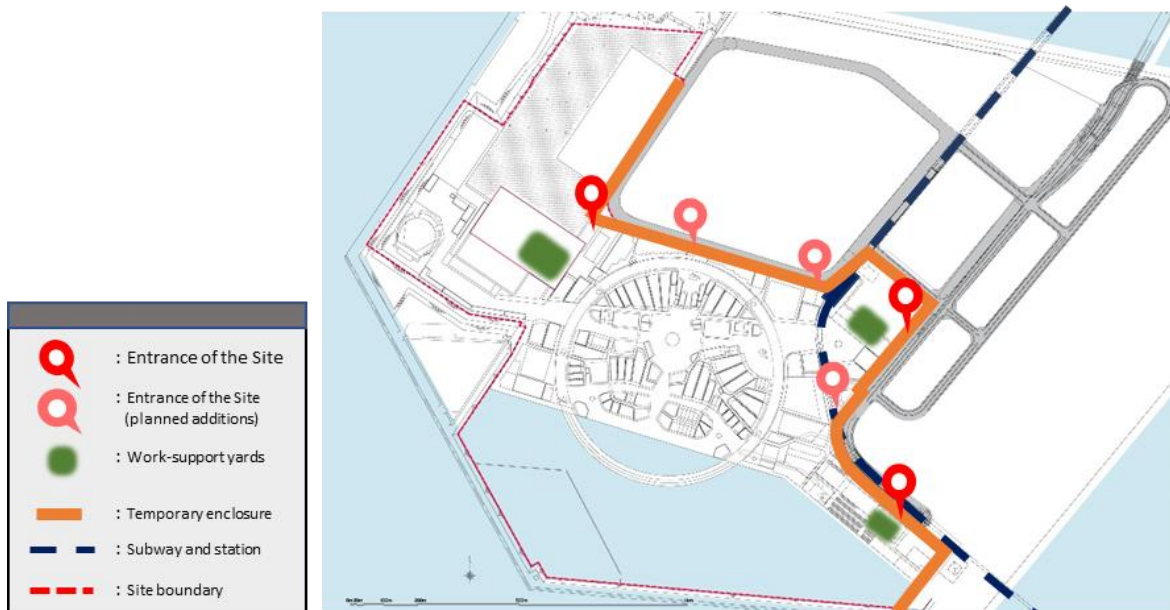

\*Subject to change depending on the status of constructions in the Expo Site.

### 5-1-3. Control of Construction/Commuter Vehicles Within Entire Expo Site

In Yumeshima Island where the Expo Site is located, construction work for the Expo, that for IR, and work to establish infrastructure such as roads and subways within Yumeshima are conducted in parallel. Therefore, there is concern that the number of construction vehicles and commuter vehicles (hereinafter referred to as "Construction-related Vehicles") is significantly increased, resulting in traffic jam in and around Yumeshima Island. With this situation in mind, Participants and their contractors shall consider and execute a vehicle management plan that takes into account traffic conditions, including restriction on the number of the Construction-related Vehicles and staggered entry/exit.

- C-080** Participants shall limit the number of the Construction-related Vehicles to the minimum.
- C-081** Participants shall report the scheduled entry/exit time and the number of the Construction-related Vehicles to the General Contractor as specified in the rules established by the Organiser. In addition, Participants shall revise their plan based on the results of the General Contractor's review and coordination concerning the entry/exit time and the number of the Construction-related Vehicles across the Expo Site as well as in each section.
- C-082** The Organiser has introduced a traffic control system for the Construction-related Vehicles. Participants shall register their Construction-related Vehicles in advance as specified in the rules established by the

Organiser. Participants shall pay the costs for establishing the traffic control system and construction vehicle management equipment to the Organiser or General Contractor when request for the burden.

#### 5-1-4. Consideration Towards Natural Environment

On Yumeshima Island, which is the planned venue of the Expo Site, rare wild fauna and flora species listed in the “Ministry of the Environment’s Red List 2020” and the “Osaka Prefecture’s Red List 2014,” etc. are observed. Therefore, consideration towards natural environment is required in executing various types of construction work within the Site.

**C-083** As rare wild fauna and flora species are observed within and around the planned Expo Site, Participants shall ensure that appropriate conservation measures in accordance with the Organiser’s instructions, such as using low-noise and low-vibration construction machine and reviewing the direction and brightness of night lighting, are implemented.

**C-084** Participants shall ensure all the construction personnel understand that appropriate measures shall be taken in consideration of the fauna and flora in and around the Expo Site, such as giving orders to prohibit unnecessary entry to areas outside of their construction site.

#### 5-2. Construction Work Plan for Interior/Exterior Work etc.

Participants will be implementing Interior/Exterior Work etc. of their Pavilions concurrently as the construction work of several other facilities are carried out within the Expo Site until the end of the Expo period. Therefore, Participants shall comply with the rules of construction work within the Expo Site, including those specified in this Chapter, as well as the rules of construction work separately established by the Organiser and prepare a construction work plan.

**C-085** Participants shall submit the work plan for their Interior/Exterior Work etc. to the Organiser via the online portal for the Official Participants at least 15 days before the commencement of the construction work. The construction work plan shall detail the organisational structure, work schedule, and other matters related to the Interior/Exterior Work etc. of a Participant. The following are key components which should be described in the construction work plan:

- Organisational structure for construction
- Overall work schedule of the Interior/Exterior Work etc. etc.
- Schematic installation plan for temporary construction facilities (including lifting plan, etc.)
- Health and safety plan (please refer to Chapter 6)
- List of key materials (the volume and delivery timing of planned materials [including service water])
- Number of workers (the planned number of workers and their work timing)
- Number of Construction-related Vehicles (the planned number and usage timing of construction vehicles, commuter vehicles, and construction machine)
- Volume of waste to be disposed of (planned volume and timing)
- List of emergency contact
- Security control within the Exhibition Space
- Other construction work-related documents required by the Organiser

**C-086** Participants shall implement necessary measures to mitigate risks and an impact on the adjoining plot(s) and the entire Expo Site. Participants shall ensure that their work plans will involve no wastewater drainage within their plots during the period before the Organiser gives them permission to use the wastewater drains.

- C-087** Participants shall not cause damage to facilities, etc. of the Organiser and other Participants, regardless of whether they are finished or under construction, during the Interior/Exterior Work etc. of their Pavilions. Participants shall apply protections to completed buildings, exterior structures, pieces of equipment, and other features as necessary.
- C-088** Participants shall report any damage they or their contractors cause in their execution of construction work within the Expo Site to the Organiser and take responsibility for such damage. If the Organiser demands that the Participant concerned should repair the damaged works or reimburse the repair costs paid by the Organiser or the other Participants, the Participant concerned shall satisfy the demand.
- G-033** It is desirable that Participants, in executing their construction work, strive to level the amount of construction work taking into account the number of construction vehicles and the impact of noise and vibration.
- C-089** Participants shall provide security staff to control the traffic as necessary.
- C-090** Participants shall appropriately maintain and manage the entrances by regularly conducting inspection, cleaning, and maintenance.
- C-091** Participants shall appropriately maintain and manage temporary construction facilities and ensure that they remain safe in the wake of disasters such as typhoons and earthquakes.
- C-092** Participants shall install construction signage in their plots at a location close to each entrance and ensure that these signs are always clearly readable. Participants shall present the following items on the construction signs.
- Information on the Pavilion (the participants, Commencement of Construction Permit number, etc.)
  - Construction license list
  - Organisational structure chart
  - Emergency contact
  - Labour insurance: notification on establishment of insurance relations
  - Chief manager of work
  - Other necessary signs
- C-093** Participants shall erect temporary enclosures at the boundaries of the plots. The posts and other elements of the temporary enclosure shall be located within their plots.
- C-094** Participants shall not display any advertising-related displays on the temporary enclosure without the prior permission of the Organiser.
- C-095** Participants shall establish as necessary an on-site station and workers' rest areas within their plots during the work period.

#### 5-2-1. Schematic Installation Plan for Temporary Construction Facilities

- C-096** Participants shall prepare a schematic installation plan for temporary construction facilities and submit it with the construction work plan to the Organiser via the online portal for the Official Participants. The following are items that should be included in the schematic installation plan for temporary construction facilities:

- Planned locations of construction machine/vehicles
- Plan for outer scaffolding
- On-site station, workers' rest areas, materials and equipment storage area, and other spaces
- Electrical equipment for construction and water supply equipment (tanks) for construction
- Waste storage area

#### 5-2-2. Temporary Infrastructure during Construction Work

- C-097** Participants shall make necessary arrangement for temporary infrastructure after coordinating with the General Contractor until the Organiser provides infrastructure such as a water supply system, electrical equipment and sewer pipes. Please note that the Organiser set up several shared water supply facilities as provisional infrastructure within the Expo Site. The use of the facilities is monitored by the General Contractor, and if a possible shortage is identified, the facilities may be expanded, etc. In addition, the Organiser shall assess and secure the market situation for temporary starting generators and provide them to the Participants. The Participants can procure water necessary for their Exhibition Spaces which are handed over to them during the construction period from the said water supply facilities. The timing of the commencement of infrastructure services established by the Organiser is notified to Participants by the Organiser via the online portal for the Official Participants.
- C-098** Participants shall bear the costs for temporary infrastructure such as a water supply system, electrical equipment and sewer pipes until infrastructure services provided by the Organiser are commenced. In addition, Participants shall pay electricity bills to the Organiser once the services of official electrical equipment commence.
- C-099** Participants shall collect and treat sewage appropriately in compliance with the Laws and Regulations as well as the rules established by the Organiser. Participants shall give due consideration to the safety of a power generator in its installation to prevent fires and other disasters.

#### 5-2-3. Transportation and Storage of Building Materials

- C-100** Participants shall transport building materials required for their Interior/Exterior Work etc. into their Exhibition Spaces in compliance with the operation rules established by the Organiser and appropriately store them under their own responsibility. The Organiser plan to set up storage areas for materials and other items outside the venue. The Organiser will inform Participants via the Official Participant Portal when and how to start using the storage areas for materials and other items outside the venue.
- C-101** Participants shall rent vehicles and construction machines that are necessary for the transportation of building materials, etc. into their Exhibition Spaces themselves and take responsibility for the transportation and storage of building materials and other items.
- C-102** When Participants plan to have transportation vehicles come to/go out of the Expo Site, they need to work with the General Contractor to make necessary coordination taking into account other Participants'

schedule. Therefore, Participants shall report the number and scheduled timing of vehicles which come to/go out of the Site, pursuant to the rules established by the Organiser.

**C-103** If the Organiser demands to do so, Participants shall have transportation vehicles go through security check before they are allowed to come into the Expo Site. Participants shall plan their work schedule taking into account the time necessary for such security check. Please note that the time required for the security check depends on the types and contents of goods loaded on each vehicle.

**C-104** When Participants unload transported building materials on the site passageway, they shall be required to submit to the General Contractor an application for unloading materials outside the plot in advance and obtain its permit for the work.

#### 5-2-4. Waste Management and Disposal

**C-105** Participants shall separate wastes generated from the Interior/Exterior Work etc. within their plots and appropriately store them.

**C-106** Participants shall dispose of wastes generated from the Interior/Exterior Work etc. in compliance with the Laws and Regulations and strive to curb and recycle such wastes.

**C-107** Participants shall separate wastes generated during the Interior/Exterior Work etc. by type within their plots as much as possible and strive to recycle them by handing them over to intermediate waste disposal companies.

**C-108** Participants and their contractors shall achieve the following construction waste-related objectives set out in the “Construction Recycling Promotion Plan 2020” (September 2020, the Ministry of Land, Infrastructure, Transport and Tourism).

Item	Indicator	Goal for 2024
Asphalt/concrete lumps	Recycling rate	99% or higher
Concrete lumps	Recycling rate	99% or higher
Construction generated wood	Recycling/reduction rate	97% or higher
Construction generated sludge	Recycling/reduction rate	95% or higher
Mixed construction waste	Discharge rate	3.0% or lower
Overall construction waste	Recycling/reduction rate	98% or higher

**C-109** Participants shall strive not to generate waste by simplifying packing materials and try to reduce waste by separating various types of wastes with separation containers.

**C-110** Participants shall arrange regular waste collection.

**C-111** Drainage during the work shall be appropriately neutralised and disposed at places instructed by the Organiser.



#### 5-2-5. Use of Construction Machine

- C-112** When Participants use construction machine such as cranes in their Interior/Exterior Work etc. and coordination with neighbouring Plots is required, the said Participants and their contractors shall report matters to be coordinated to the General Contractor and obtain its approval.
- C-113** Participants shall, in executing specified construction work in which construction machine is used, submit an implementation notification of specified construction work pursuant to the Noise Regulation Act, the Vibration Regulation Act, and the Osaka Prefectural Ordinance on Maintenance of Living Conditions.
- C-114** Participants shall proactively use low-emission construction machine designated by the Ministry of Land, Infrastructure, Transport and Tourism in terms of construction machine.
- C-115** Participants shall proactively use low-noise and low-vibration construction machine designated by the Ministry of Land, Infrastructure, Transport and Tourism in terms of construction machine.
- C-116** Participants shall strive to reduce exhaust emissions and mitigate noise and vibration by preventing unnecessary idling of engines and avoiding simultaneous operation as much as possible when using construction machine.
- G-034** It is desirable that Participants use construction vehicles/machine that are run by electricity, a fuel cell, environmentally friendly fuels such as biofuels or hybrid technology, etc. to the extent possible.

#### 5-2-6. Hours When Interior/Exterior Work etc. May Be Carried Out

As a rule, Interior/Exterior Work etc. may be carried out from 8:00 to 18:00 within the Expo Site. If there is a specific reason in developing the Expo Site or an emergency, the Organiser may order the suspension of construction work within the Site or the closure of the Site, or instruct relevant parties to leave the Site. In that case, Participants shall follow the order.

- C-117** In principle, construction work at night or on weekends and holidays is prohibited. If construction work need to be carried out at such hours, Participants shall obtain the permission of the Organiser in advance.
- C-118** When carrying out night-time work, Participants shall try to minimise such work while appropriately taking care of noise and other nuisances, and mitigate any impact on fauna and flora around the planned Expo Site as much as possible by adopting appropriate shading hood and placing lighting equipment at right places.

### 5-3. Security During Construction Work

The Organiser will implement security control in accordance with the progress of the construction work of the entire Expo Site. If security control measures are updated, their details are planned to be announced to Participants via the online portal for the Official Participants.

#### 5-3-1. Responsibility for Security Measures

The Organiser will manage access to the Expo Site and traffic therein and issue admission/certificates of vehicle traffic permit, etc. valid during the construction work. Participants shall bear responsibility for the loss or damage of valuables. The Organiser will not compensate any loss or damage.

- C-119** Participants shall always secure emergency route to enter their Exhibition Spaces so that the Organiser can immediately respond to any emergency such as fire.

- C-120** If emergencies such as fire and an accident during construction work occur, Participants shall immediately report them to the Organiser and take emergency response measures. For the details of communication/reporting at the time of emergencies, please refer to Chapter 8.
- C-121** Participants shall prohibit construction personnel from unnecessarily entering into other places than their Exhibition Spaces.
- G-035** It is desirable that Participants implement security measures such as putting surveillance guards in place and recording the entry/exit of construction personnel to/from their plots as well as work done in order to protect the building, equipment and other assets within their plots. The Organiser will not protect the assets of Participants, and will never compensate loss or damage if any problems concerning such assets arise.
- G-036** It is desirable that Participants manage important facilities in their Exhibition Spaces by installing locking devices.
- G-037** It is desirable that Participants minimise the exposure of cables in their Exhibition Spaces by using electrical/communication wire conduits so that the cables are not visible from outside.

#### 5-3-2. Location of Security Check

The Organiser will carry out security checks on entering/exiting vehicles and construction personnel at the entrances of the Expo Site.

- C-122** The Organiser will put gate security guards in place to check certificates of vehicle traffic permit, admission passes, and entry permits discussed later and perform other tasks. Participants shall reimburse security check-related costs to the Organiser or the General Contractor when request for the burden.

#### 5-3-3. Certificate (pass) of Vehicle Traffic Permit

- C-123** All the vehicles that enter into the Site shall present a certificate of vehicle traffic permit issued by the Organiser by placing it on the windshield. Participants shall apply for the certificates of vehicle traffic permit to the Organiser via the online portal for the Official Participants at least 3 days before the vehicle concerned arrives at the Site.
- C-124** Vehicles of visitors shall be registered with the traffic control system in advance and present a certificate of vehicle traffic permit or an alternative document at the guard station that are planned to be established near the entrance gates of the Expo Site. The vehicles of visitors shall be parked in the spaces within the designated work-support yard.
- C-125** Participants and their contractors shall strictly comply with the traffic rules established by the Organiser that are applicable within the Site. The Organiser may impose restrictive measures on those who violate such traffic rules, including the revocation of vehicle traffic permits.

#### 5-3-4. Admission Pass

- C-126** Construction personnel who enter to the Expo Site, including Participants and their contractors, shall obtain admission passes issued by the Organiser. All the construction personnel shall always carry their admission pass.
- C-127** Participants shall apply for the admission passes for construction personnel to the Organiser via the online portal for the Official Participants. The following are required documents to be attached:
- Health insurance card (national health insurance and social insurance)
  - Copy of passport (only for those with foreign nationality)
  - Copy of work visa valid in Japan (only for those with foreign nationality)
- C-128** Participants shall apply for the admission passes to the Organiser via the online portal for the Official Participants at least one day before the relevant construction personnel arrive at the Expo Site. Please note that if Participants want to apply for more than ten admission passes at a time, in order to ensure efficient issuance procedures, the application shall be made at least three days before the relevant personnel arrive at the Site.

#### 5-3-5. Entry Permit (Temporary Permit)

- C-129** All visitors shall either obtain an entry permit or register with an alternative system before entering into the Expo Site. An entry permit will be issued at guard stations that are planned to be established near the entrance gates of the Expo Site after a security guard confirms the visitor's official ID (driver's license, etc.), destination, and whether the visitor comes by car (if a vehicle traffic permit is necessary), etc.
- C-130** Participants and their contractors shall pick up and drop off the visitor between the work-support yard and the destination.

#### 5-4. Permit for Work Outside of the plot

- C-131** When temporarily carrying out construction work outside of their Exhibition Spaces, Participants shall submit a work-outside-of-the-Plot application to the General Contractor in advance and obtain its permit. The said work-outside-of-the-Plot application shall be accompanied by a work-outside-of-the-Plot plan that describes the summary of the work (such as its timing and what will be done) to be conducted outside their Exhibition Spaces.
- C-132** As the General Contractor shall coordinate work outside the plot of different Participants to issue a permit for such work, Participants shall notify the Organiser or General Contractor as early as possible taking into account the schedule of their work outside the plot. Participants shall comply with the rules established by the Organiser in terms of the timing of application.

## 5-5. Roads and Traffic Control

In order to ensure safe and timely transportation, the Organiser will implement traffic control in all the areas within the Expo Site.

Figure 5.5 Entrance of the Site

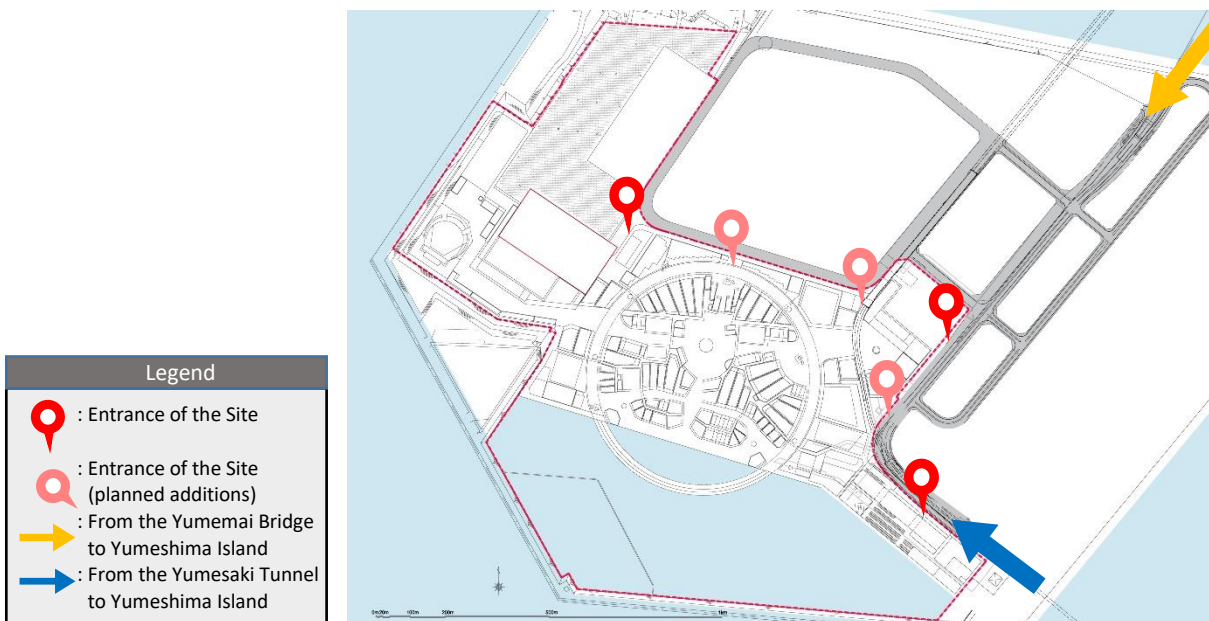

\*Subject to change depending on the status of constructions in the Expo Site.

### 5-5-1. Access to the EXPO Site

- C-133** Participants shall appropriately plan the vehicle routes and use expressways as much as possible so that there would be least impact of work-related movement of their vehicles on the surrounding area, including Yumeshima Island on which the Expo Site is planned.
- C-134** The Organiser plans to introduce commuter buses that may be used by construction personnel in order to reduce the number of vehicles that go into/out of the Site. Participants shall reimburse commuter buses-related costs to the General Contractor. The Organisers have also set up parking areas outside the venue for use by construction workers and others. The Organiser will inform participants via the Official Participant Portal about when and how to start using the parking areas.
- C-135** Regarding access to the Expo Site and transportation, Participants shall comply with road traffic-related Laws and Regulations in Japan, including restrictions on traffic within Yumeshima Island, and follow the instructions of traffic/road administrators.
- C-136** Regarding the delivery of construction materials, exhibits and other items, Participants shall consider appropriate hours for construction vehicles to travel the designated routes, ensure that construction vehicles do not obstruct pedestrians, ensure that drivers drive in an appropriate manner, and control the operation of the Construction-related Vehicles.
- C-137** When planning transportation to the Expo Site, Participants shall consider traffic conditions in the surrounding areas, including Yumeshima Island that is the planned Expo Site.
- C-138** Participants shall optimise the schedule of delivery/carrying out of building materials, products, etc. by ordering an appropriate amount of materials, in order to reduce the number of vehicles.

- C-139** Commuter vehicles, vehicles that transport building materials, and other vehicles shall strive to avoid unnecessary idling of engines, reduce exhaust emissions, and mitigate noise.
- C-140** Vehicles that enter into the Site, in principle, shall not bring in prohibited goods, such as animals and plants, alcohol, medicine not authorised in Japan, illegal drugs, explosives, etc.  
Letters and packages may be transported to each plot using the designated routes once delivery persons obtain an entry permit at guard stations established by the Organiser near the entrance gates of the Site.

#### 5-5-2. Entrance of Site

The entrances of the Site may be changed for operational reasons. If the entrances of the Site are changed, it will be announced via Participant Portal in advance.

#### 5-5-3. Passageway within Site

The Organiser will secure routes for construction vehicles to the Exhibition Spaces of Participants within the Expo Site. Available Routes for construction vehicles are adjusted in accordance with the progress of the construction work of facilities relating to common areas within the Site and that of infrastructure and announced them to Participants via the Communication and Coordination Council. The Organiser plans to asphalt the routes for construction vehicles after the completion of infrastructure work.

- C-141** Participants shall not put building materials, construction vehicles, etc. on passageways within the Site without the permit of the Organiser.
- C-142** When Participants need to temporarily use part of passageways within the Site, they shall submit an application to the General Contractor in advance and obtain its permit as set out in “5-4. Permit for Work Outside of Exhibition Space.”
- C-143** Participants shall not have construction vehicles and other vehicles park or wait on passageways within the Site.

#### 5-5-4. Traffic Signage and Lighting within Site

The Organiser will ensure the security of traffic within the Site by put traffic signage and lighting on passageways for construction appropriately.

- C-144** When lighting for construction is required in their plots, Participants shall put lighting equipment in place in an appropriate manner and maintain it.

#### 5-5-5. Traffic Control within Site

Participants and their contractors shall comply with road traffic-related Laws and Regulations in Japan and follow the instructions of the Organiser on the roads within the Site too.

- C-145** Participants and their contractors shall comply with road traffic-related Laws and Regulations in Japan, such as limiting the speed of their vehicles within the Site, using seatbelt while driving, and avoiding using mobile devices while driving. Please note that the maximum speed allowed on the passageways within the Site plans to be set at 20 km/h, but it may be different at certain places. In addition, to ensure the safe passage of vehicles within the Site, comply with the Organiser-established traffic rules and traffic signage.

**C-146** Construction vehicles shall go out from the Site to public roads only after washing their tyres with tyre washing equipment in order not to pollute public roads and to prevent dusts from scattering. The tyre washing equipment has been installed by the Organiser.

## 5-6. Security Measures When Constructing Concealed Spaces

**C-147** Upon the Organiser's request, Participants may have inspection of concealed spaces before they are sealed off during the work. In addition, the Organiser may request that it inspects equipment or materials with a concealed space before Participants bring them into the Site. Participants shall plan their work schedule taking into account the possibility of such inspection. Please note that the time required for the inspection depends on the types and contents of goods loaded on each vehicle.

## 5-7. Construction Progress Report

**C-148** Participants shall submit a construction progress report to the Organiser every month via the online portal for the Official Participants. The construction progress report shall include the following information:

- Overall work schedule (which shall clearly show the value of work done and the progress)
- Work schedule for the following month
- Work progress report for the current month
- Pictures of work progress for the current month (including pictures of fixed-point observations)
- Implementation status of health and safety management (the total number of workers / the total number of working hours / presence or absence of accidents, etc.)
- Environment-related data report
- Report on important issues (situations concerning an accident, etc.) relating to the Organiser and third parties
- Report on the progress of actions to correct non-conformance (if a non-conformance report has been issued)
- Other performance report required by the Organiser

**C-149** Participants shall submit a construction progress report on the date designated by the Organiser every month via the online portal for the Official Participants, starting at the planning phase.

### 5-7-1. Confirmation of Environment-related Data and Report to the Organiser

**C-150** Participants shall have their contractors collect environment-related data every month. If there is any issue, Participants shall clarify the characteristics of the issue and report it, along with proposed solution, to the Organiser or General Contractor. The format of the environment-related data report is available via the online portal for the Official Participants. The following are environment-related data that Participants shall collect every month:

- Construction-related Vehicles (number, the time slot of operation, routes)
- Construction machine vehicle (number and hours to operate)

- Amount of waste generated (disposed) (the recycle rate of waste and the destination of waste disposed)
- Amount of excess soil generated (disposed)
- Amount of sludge generated (disposed)
- Amount of human waste generated (disposed)
- Amount of electricity used
- Amount of service water used
- Amount of sewage used (amount to be treated)
- Types and amounts of fuel used in the venue (construction machine / power generators)

**C-151** Participants shall conduct regular inspection to ensure that their contractors take measures to protect the environment in accordance with “Chapter 7: Sustainability Efforts” herein.

### 5-8. Documents to be Submitted

The following are documents concerning this Chapter that the Organiser requires Participants to submit. The documents are to be submitted to the Organiser via the online portal for the Official Participants. Designated formats for documents to be submitted will be made available on the online portal for the Official Participants.

Names of documents to be submitted:

- Construction work plan (5-2)
- Schematic installation plan for temporary construction facility (5-2-1)
- [If necessary] Application form for outside-of-the-Exhibition-Space unloading (5-2-3)
- [If necessary] Application form for the use and coordination of construction machine (5-2-5)
- Application form for construction at night and on weekends/holidays (5-2-6)
- Application form for a certificate of vehicle traffic permit (5-3-3)
- Application form for an admission pass (5-3-4)
- Application form for an entry permit (5-3-5)
- Work-outside-of-the-Exhibition-space application form (5-4)
- Construction progress report (5-7)
- Environment-related data report (5-7-1)

### 5-9. Reminders of Standards Referred to in This Chapter (Supplementary Information)

- Building Standards Act
- Noise Regulation Act
- Vibration Regulation Act
- Osaka Prefectural Ordinance on Maintenance of Living Conditions
- Air Pollution Control Act
- Construction Material Recycling Act
- Construction Recycling Promotion Plan 2020
- Information of Yumeshima-related construction work
  - Yumeshima Island Development Project Coordination Council:
    - <https://www.city.osaka.lg.jp/kensetsu/page/0000478281.html>
  - Communication Council for Smooth Progress of the Expo Project at Yumeshima Island:
    - <https://www.city.osaka.lg.jp/kensetsu/page/0000506669.html>

## 6. Securing of Occupation Safety and Health

This Chapter describes labour environments, safety, and health environments that Participants need to secure in work sites when implementing their works.

### 6-1. Compliance with Laws and Regulations Concerning Occupational Safety and Health

**C-152** In implementing the work, Participants shall comply with Japanese laws, including the Act on Labour Standards and the Act on Labour Safety and Health, and relevant laws and regulations, including Ordinances of the Osaka Prefecture and Osaka City.

### 6-2. Policy on the Sustainable Operation of the Expo

To make this Expo a role model for future expositions and other international events, attention will also be paid to sustainability of occupational safety and health in the work. Participants are to enable sustainability based on the Policy on Holding a Sustainable Expo 2025 Osaka, Kansai, Japan, which the Organiser separately prepared to describe details, as well as the following items that are pursuant to the Policy. Sound workplace environments that are mindful of workers health are to be secured.

**C-153** Contractors are to be mindful of workers health management. To prevent heat strokes particularly during constructions in the summer, on-site health environments and workers health conditions must be thoroughly managed. Emergency measures for any occurrences of heat strokes must be determined in advance, and any such occurrences must be attended to promptly. Refer to Chapter 8 for reporting on any occurrences of heat strokes.

**G-038** To prevent long-hour labour, it would be preferred if Participants and contractors consider implementing construction plans and processes that allow all workers to rest two days a week (eight holidays in four weeks).

### 6-3. Development and Submission of Safety and Health Plans by Contractors

**C-154** Contractors must develop safety and health plans within construction plans indicated in Chapter 5 and submit them. The following are items that should be included in the safety and health plan.

- > On-site safety and health
- > Rules and routine operations at work areas

### 6-4. Occupational Safety and Health Management by Participants

**C-155** Participants must support contractors in appropriately operating construction sites based on laws and regulations and this Guideline. Further, Participants are to confirm progress to check if there are any problems in the operation of construction sites.

### 6-5. Reporting on Accidents

**C-156** If any accidents occur in relation to constructions, Participants must report them to the Organiser. Refer to Chapter 8 for accidents that require notification and reporting as well as details on procedures and methods of doing so.

### 6-6. Documents to be Submitted

The following are documents concerning this Chapter that the Organiser requires Participants to submit. The documents are to be submitted to the Organiser via the online portal for the Official Participants. Designated formats for documents to be submitted will be made available on the online portal for the Official Participants.



Names of documents to be submitted:

- Safety and health plans and attachments (to be included in Construction work plan 5-2)

### **6-7. Reminders of Standards Referred to in This Chapter (Supplementary Information)**

- > Act on Labour Standards: Applicable operators' report
- > Act on Labour Standards: Agreements on overtime and holiday work
- > Act on Labour Standards: Notification of agreement on one-year-unit variable working hour system
- > Act on Labour Safety and Health: Notification on construction plans
- > Act on Labour Safety and Health: Notification on constructed structures and machine instalment
- > Act on Labour Safety and Health: Report on commencement of projects by special principal employer operators

## 7. Sustainability Efforts

This Chapter describes sustainability efforts and the environmental impact assessment system (environmental assessment system).

### 7-1. Policy on Sustainability and Sustainable Procurement Code

Based on its theme Designing Future Society for Our Lives, the Expo aims to become an exposition that provides an opportunity for the world to convene in one place, prompts the exchange of diverse values, and facilitates new connections and creation.

To make this Expo a role model for future expositions and other international events, it will appropriately manage its impact on the environment and the society during and after the Expo from pre-exposition planning stages and thus, take heed of sustainability.

For this, the Organiser developed the Policy on the Sustainable Operation of the Expo and Sustainable Procurement Code. These documents are available on the online portal for the Official Participants.

**C-157** Participants shall comply with the Policy on the Sustainable Operation of the Expo and perform constructions that are mindful of sustainability.

**C-158** Participants shall perform constructions in compliance with the Sustainable Procurement Code.

### 7-2. Environmental Impact Assessment System (Environmental Assessment System)

This project conducts an environmental impact assessment system (environmental assessment system) based on Osaka municipal ordinance on environmental impact assessment. The environmental impact assessment system (environmental assessment system) is a system in which the Organiser itself researches, forecasts, and assesses in advance what kind of impact the Expo will have on the environment and while interviewing residents for their opinions, takes proper action to preserve and create environments.

Participants are to confirm the Environmental Impact Assessment Document (hereinafter referred to as "Assessment Document") which the Organiser published in June 2022 and reflect its content in the Interior/Exterior Work etc. and its removal work.

The Assessment Document is available on the website of the Organiser.

**C-159** Participants are to plan and carry out construction work so that they meet criteria set forth in the Assessment Document that the Organiser has published.

**C-160** The Organiser may instruct necessary measures according to the scale of each Participant's construction work, such as limitation on the number of construction-related vehicles, and Participants shall comply with these instructions. The content of specific measures will be separately notified.

### 7-3. Reminders of Standards Referred to in This Chapter (Supplementary Information)

- Policy on the Sustainable Operation of the Expo
- Sustainable Procurement Code
- Environmental Impact Assessment Document

[https://www.expo2025.or.jp/association/maintenance/environmental\\_impact\\_assessment/](https://www.expo2025.or.jp/association/maintenance/environmental_impact_assessment/)

## 8. Information Management System and Compliance with Quality Control

This Chapter describes information management systems required of Participants and procedures for notifications within them, as well as quality control.

### 8-1. Procedures and Methods of Notifications

Participants are to notify and consult with the Organiser via the online portal for the Official Participants.

#### 8-1-1. Coordination between Participants

**C-161** If any matters that require coordination between Participants arise, such as those concerning the boundaries between adjacent Exhibition Spaces, the involved Participants shall discuss the matters and resolve them amongst themselves. For matters requiring coordination with the Exposition Venue overall, Participants shall coordinate with the Organiser.

**C-162** In the event any matters requiring coordination arise between Participants, both parties shall retain records and report about the matters, including the background of the matters, if requested by the Organiser.

#### 8-1-2. Notification and Reporting in Emergencies

**C-163** In the event of any accidents within plots, Participants must report them to the Organiser and take emergency measures required immediately after the accident. Figure 8.1 indicates procedures for reporting when accidents arise. The first report immediately after the accident must be made, and the second and third document-based reports are to be made as needed. After attending to the accident, Participants shall put together respective document-based reports, prepare an accident report which include recurrence prevention measures, and submit the reports to the Organiser via the online portal for the Official Participants. Additionally, when accidents occur for reasons attributable to relevant parties of the Participants, the Participants must report them based on the same procedures, even if the accident occurred outside of the Participants' Exhibition Spaces.

**C-164** The following indicates accidents that require reporting to the Organiser.

- > Accidents defined in the Labour Safety and Health Regulations (described in (1) through (4) below)
  - ① If any deaths or serious occupational hazards and accidents (those affecting three or more persons, as a general rule) occur
  - ② If workers take a leave of absence due to occupational hazards (leaves of absences of four or more days, as a general rule)
  - ③ When fires, explosions, and collapses of construction machines occur (if accidents indicated in Article 96, Paragraph 1, Item 1-10 in the Labour Safety and Health Regulations occur)
  - ④ Otherwise, if affected workers are treated at hospitals, even if the injuries are mild, and the accident is reported to the Labour Standards Inspection Office as occupational hazards
- > Cases that affect the environment (such as large-scale oil leakage)
- > Acts or physical damage that inhibit activities of the Organiser or Participants, or if there are any serious effects on other Participants

- > If there are any serious effects on third parties
- > If any other events that would prompt reporting to the police or fire department occur
- > If there are any violations concerning the security of the Exposition Venue
- > If any disadvantageous media coverage on the Expo or acts that may diminish the reputation of the Organiser occur for reasons attributable to Participants

**C-165** Participants must indicate its reporting procedures for accidents as well as persons responsible and relevant parties in case of accidents in the List of Emergency Contact submitted as part of the Construction Work Plan. For further information, please refer to Chapter 5.

**C-166** Participants shall record all accidents that occur within the plots as well as accidents outside their plots that are attributable to their relevant parties and report them to the Organiser in the Construction Progress Report. For further information, please refer to Chapter 5.

Figure 8.1 Reporting procedure at times of accidents

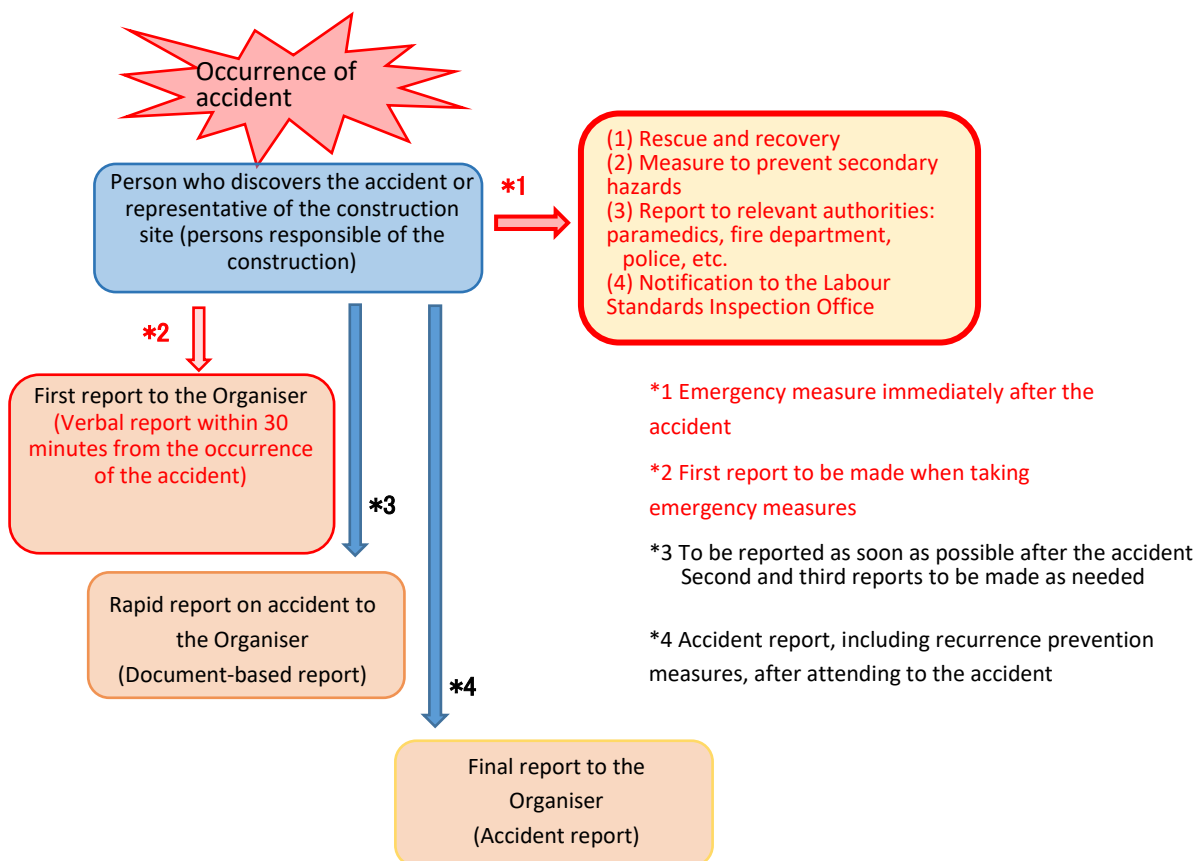

## 8-2. Notification and Measures for Violation of Rules

In the event that the Organiser identifies any violation of contractual clauses provided in Participation Contract or provisions in this Guidelines document (violations of Laws and Regulations or false reports), or otherwise, in the event that accidents requiring report to relevant parties arise, the Organiser will issue a non-conformance notice (instructions on improvement) to the Participants. Participants to whom non-conformance notices (instructions on improvement) are issued shall not continue further operations until the Organiser approves of corrections to the identified violations. Refer to 8-3-2: Periodic confirmation regarding status of supervision for detailed examples

of cases in which non-conformance notices (instructions on improvement) are issued due to violations of laws and regulations or false reports.

### 8-3. Quality Control

Participants are to control quality in compliance with relevant laws and regulations, such as the Building Standards Act of Japan.

**C-167** Participants shall obtain Certificate of Completion and Users Permit from the Organiser after completing their interior/exterior work etc.. In doing so, Participants shall submit to the Organiser inspection reports via the online portal for the Official Participants and guarantee quality control that is compliant with relevant Japanese laws and regulations. Formats for the inspection reports will be posted on the online portal for the Official Participants as of plan. For further information, please refer to Chapter 10.

#### 8-3-1. Supervision System to Secure Quality

To secure the quality of Exhibition Spaces and exhibited items, Participants must support contractors and periodically confirm the status of construction management that contractors perform. To secure the quality of the Expo, the Organiser will periodically confirm the status of construction management that contractors perform. Please refer to 8-3-2. Periodic confirmation regarding status of supervision.

#### 8-3-2. Periodic Confirmation Regarding Status of Supervision

To confirm if Participants' contractors are complying with construction requirements provided in relevant standards and this Guidelines document, the Organiser will confirm Construction Progress Reports (refer to Chapter 5). The Organiser will confirm reports and photos on the status of construction work within the Construction Progress Report, and if the Organiser determines that correction need to be made in the status of construction management performed by the contractors, the Organiser will require the Participants to make corrections. If improvement cannot be observed within a certain period after the corrections are required, the Organiser may issue a non-conformance notice (instructions on improvement) provided in 8-2. Notification and measures for violation of rules to the Participants. Participants are to use effort to prepare documents based on latest information.

**C-168** Participants shall retain records of the inspections and tests performed by their contractors.

### 8-4. Documents to be Submitted

The following are documents concerning this Chapter that the Organiser requires Participants to submit. Documents that need to be submitted are to be submitted to the Organiser via the online portal for the Official Participants. Designated formats for documents to be submitted will be made available on the online portal for the Official Participants.

Names of documents to be submitted:

- Inspection report (8-3)

### 8-5. Reminders of Standards Referred to in This Chapter (Supplementary Information)

- Standard Specifications on Public Construction Work
- Labour Safety and Health Regulations
- Building Standards Act and Order for Enforcement of the Act

## 9. Interior/Exterior etc. Removal Work and Return of Exhibition Space

This Chapter describes procedures and rules for interior/exterior etc. removal work and Return of Exhibition Space.

**C-169** The Participants shall remove the interior and exterior of the building that they themselves has constructed, the outbuilding that they have maintained and the exhibits that they have installed, and shall restore them to the same condition as when they were first received. The demolition of the returned building shall be carried out by the Organiser.

### 9-1. Schedule-related Conditions in Interior/Exterior etc. Removal Work

**C-170** Participants are to commence the interior/exterior etc. removal work of their Pavilions after obtaining permit for the work. For the main schedule until the removal work and the return of Exhibition Space, refer to Figure 9.1.

**C-171** The removal work, including the shipping out exhibitions, should be commenced after seven days from the closing of the Expo.

**C-172** Participants shall perform their interior/exterior etc. removal work and complete the inspections by the Organiser no later than the 13th of January, 2026 before they return their Exhibition Spaces. Note, however, that Participants who are notified by the Organiser before the commencement of the restoration (removal) work to the effect that they are exempt from the obligation may return upon reaching an agreement.

Figure 9.1 Main schedule for interior/exterior etc. removal work and return of Exhibition Space

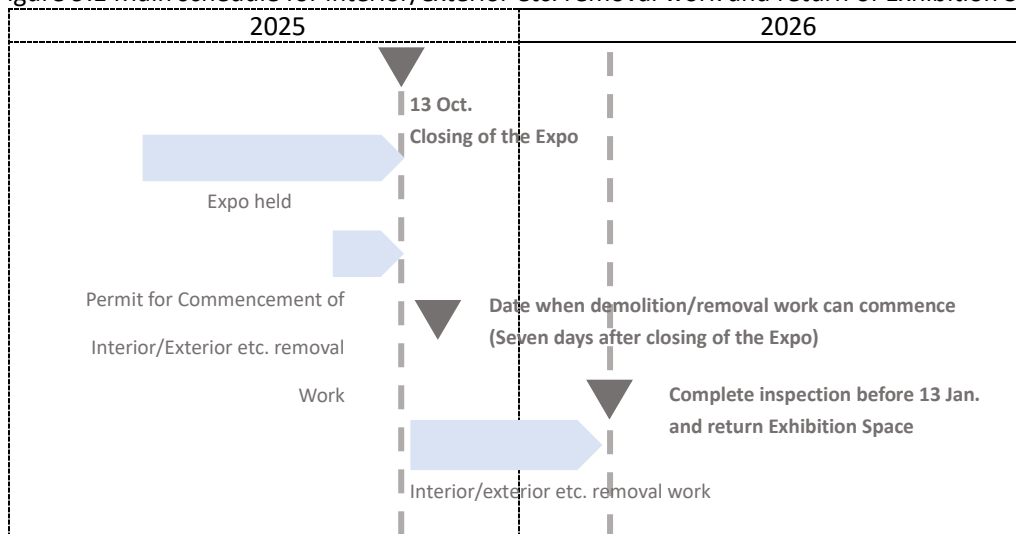

### 9-2. Requirements for Commencement of Interior/Exterior etc. Removal Work

**C-173** Participant shall apply for the Permit for Commencement of interior/exterior etc. removal work to the Organiser via the online portal for the Official Participants. Applications are to be made by 15 days prior to the planned date of work commencement. The application shall be accompanied by required documents. For further information, please refer to Chapter 10.

### 9-3. Interior/Exterior etc. Removal Work

The removal work can commence after the Organiser issues Permit for Commencement of Interior/Exterior etc. Removal Work.

**C-174** Participants and their contractors shall complete their Interior/Exterior etc. Removal Work in a manner that meets the requirements provided in Chapter 5.

**C-175** Participants shall bear responsibility of their own assets and security within their Exhibition Spaces.

### 9-4. Compliance with Occupational Safety and Health, Compliance and Quality Guarantee, and Sustainability Efforts

**C-176** Participants and their contractors shall complete their Interior/Exterior etc. Removal Work in a manner that meets requirements provided in Chapters 6 through to 8.

### 9-5. Discontinuing Use of Utility Services

**C-177** Participants are to notify the Organiser that Utility services will no longer be needed via the online portal for the Official Participants before returning their Exhibition Spaces and process final accounting procedures for all Utility services.

### 9-6. Restoration to Original State and Return of Exhibition Space

**C-178** Participants shall apply to the Organiser for on-site Return of Exhibition Space inspections via the online portal for the Official Participants website by 10 days prior to the planned date of Return of Exhibition Space. The application shall be accompanied by required documents. For further information, please refer to Chapter 10.

**C-179** Before returning their Exhibition Spaces to the Organiser, Participants shall confirm that all interior/exterior etc. installed by the Participants have been removed.

**C-180** Participants shall submit to the Organiser reports on Interior/Exterior etc. removal work. Reports shall indicate the following information.

- > Reports on inspections after the completion of interior/exterior etc. removal work that are prepared by the Participants and contractors
- > Report on the volume of generated (disposed) waste material (recycle rate of waste material and where the waste material was disposed at)
- > Photo of the Exhibition Space to indicate the condition after completing the interior/exterior etc. removal work

The Organiser will perform necessary inspections for the return of Exhibition Space, and if the Organiser determines that there are no issues, it will issue to Participants Attestation of Return of Exhibition Space, certifying the successful completion of procedures.

### 9-7. Documents to be Submitted

The following are documents that Participants are obligated to submit to the Organiser in relation to this Chapter. The documents are to be submitted to the Organiser via the online portal for the Official Participants. Designated

formats for the documents to be submitted will be made available on the online portal for the Official Participants as of plan.

Names of documents to be submitted:

- Application form for Permit for Commencement of Interior/Exterior etc. Removal Work (9-2)
- Notification on discontinuing use of Utility services (9-5)
- Application for Return of Exhibition Space inspection (9-6)
- Report on completion of interior/exterior etc. removal work (9-6)

#### **9-8. Reminders of Standards Referred to in This Chapter (Supplementary Information)**

- Building Standards Act (e.g., removal notification)
- Act on Noise Regulation
- Vibration Regulation Act
- Osaka Prefectural Ordinance on Maintenance of Living Conditions
- Air Pollution Control Act
- Construction Material Recycling Act
- Construction Recycling Promotion Plan 2020



## 10. Procedures for Notifications, Approvals, and Permits

This Chapter describes main procedures based on this Guideline (excluding procedures indicated in other Chapters) and Japanese laws.

### 10-1. Notifications by Architects, Contractors, and On-site Supervisors

If any designing is performed for building work, such activities shall be performed by architects who have architect qualifications based on laws and regulations. If any interior/exterior decoration work etc. is performed, such activity shall be performed by contractors who have obtained necessary permits pursuant to laws and regulations.

- C-181** Participants shall notify the Organiser the names and contact information of the architects. Architects are to be indicated in the application for design approval.
- C-182** Participants shall notify the Organiser on the names of contractors by 15 days prior to the commencement of construction work.
- C-183** If Participants perform Interior/Exterior Work etc., they shall appoint on-site supervisors at the construction site for communication and coordination with the Organiser and other construction parties.
- C-184** Participants shall notify the Organiser the names and contact information of the on-site supervisors by 15 days prior to the commencement of construction work.
- C-185** If the Organiser deems that on-site supervisors violated Laws and Regulations, the Organiser may instruct the Participants to dismiss the on-site supervisor in question, and the Participants shall comply with such instructions. In such case, the Participants shall immediately appoint a different on-site supervisor and notify the Organiser pursuant to the preceding Paragraph.

### 10-2. Points of Caution Concerning Documents to be Submitted

Documents can be submitted via the online portal for the Official Participants website. Note that the documents for submission shall be prepared in the PDF format accompanied by data files in their original formats (DWG or DXF for architectural drawings data). Additionally, the language used is to be Japanese.

- C-186** Documents (excluding those submitted to Related Institutions pursuant to laws and regulations) are to be submitted in formats specified in the various lists of formats. Documents submitted to Related Institutions pursuant to laws and regulations shall comply with standards and rules of authorities provided in Japanese laws and municipal ordinances. For the procedural flow of application for approvals and permits concerning design, refer to “1-3 Procedural Flow of Approval and Authorisation”.

### 10-3. Approval for Design

The procedures concerning the approval of design are defined below. The Organiser will review submitted documents and indicate items that require revision or grant approvals to the Participants via the online portal for the Official Participants. Further, this approval does not exempt Participants from their obligations and responsibilities provided in Japanese domestic laws and regulations.

If Participants perform construction work that differ from that indicated in approved plans, the Organiser may order the discontinuation of construction work.

#### 10-3-1. Submission of First Submission Documents (general Design Plan)

Following the determination of Exhibition Space allocation, Participants shall submit at least the following documents:

- An application for general design approval for the Pavilion (statement of compliance declaring the Participant complies with relevant laws and regulations of Japan, prefectural and municipal ordinances of Osaka and other regulations) and a checklist
- Ground plan and elevation drawing of the Pavilion: Scale of 1/200 or 1/100
- Standards and specifications of building materials etc.
- Technical proposal for the facilities of the pavilion
- Plans for facility load capacity and utilities
- A universal design checklist
- A planned operation schedule for design, bidding, Interior/Exterior Work etc., and Interior/Exterior etc. removal work
- A list of changes made on the documents submitted for the Application for Temporary Building Permit and a set of documents with the changes

The Organiser will review submitted documents for the first submission documents (general Design Plan) and indicate items raised, including points of revision, or grant approvals to the Participants via the online portal for the Official Participants. After approvals of the submitted documents for the first submission documents (general Design Plan), Participants may move on to the final design.

**C-187** Participants shall respond to points raised by the Organiser, including all points of revision.

#### 10-3-2. Submission of Second Submission Documents (final Design Plan)

Participants shall submit at least the following documents to elaborate on the details in the approved first set of documents:

- An application for final design approval for the pavilion (statement of compliance declaring the participant complies with relevant laws and regulations of Japan, prefectural and municipal ordinances of Osaka and other regulations) and a checklist
- Ground plan and elevation drawing of the Pavilion: Scale of 1/200 or 1/100
- A plan for the standards, specifications, and procurement of building materials etc.
- Technical proposal/specifications for the equipment
- An energy use plan (utility use plan)
- A plan regarding universal design
- A universal design checklist
- A construction/demolition plan
- The final schedule for design, bidding, Interior/Exterior Work etc., and interior/exterior etc. removal work
- A list of changes made on the documents submitted for the Application for Temporary Building Permit and a set of documents with the changes (only applicable if changes are made on the general Design Plan)

The Organiser will review submitted documents for the second submission documents (final Design Plan) and indicate items raised, including points of revision, or grant approvals to the Participants via the online portal for the Official Participants. After submitted documents for the second submission documents (final Design Plan) are approved, Participants may apply for the Permit for Commencement of Construction.

**C-188** Participants shall respond to points raised by the Organiser, including all points of revision.

#### 10-3-3. Changes to Design

**C-189** Participants shall, when they desire to change their designs, submit a Design Plan set out in this Guidelines document and obtain the Organiser's approval before implementing the work. However, if the Organiser considers that the design change is immaterial (as it clearly complies with the Guidelines), the Organiser's approval is not required. The Design Plan shall be submitted to the Organiser via the online portal for the Official Participants.

#### 10-4. Permit for Commencement of Construction

After being issued Permits for Commencement of Construction, Participants may commence Interior/Exterior Work etc.. The Organiser will review submitted documents and indicate items raised, including points of revision, or grant permits to the Participants via the online portal for the Official Participants. Further, this permit does not exempt Participants from their obligations and responsibilities provided in laws and regulations.

**C-190** To obtain Permits for Commencement of Construction, Participants shall submit to the Organiser the following documents via the online portal for the Official Participants by 15 days prior to the planned start date of construction work.

- > Application form for Permit for Commencement of Construction
- > Construction work plan
- > Pledge (concerning compliance with laws and regulations during construction work)
- > Notification on Participation in Communication and Coordination Council

**C-191** Participants may not commence construction work until they are issued Permits for Commencement of Construction.

#### 10-5. On-site Inspection

The Organiser, relevant bodies, or persons designated by the Organiser or the Related Institutions may enter construction sites and inspect the construction work.

**C-192** If the Organiser, relevant bodies, or persons designated by the Organiser or the Related Institutions deem that there are violations of laws and regulations based on the on-site inspection, they may instruct the Participants to correct the violations, and the Participants shall comply with the instructions.

#### 10-6. Procedures for Construction Completion and User Permit

When Participants complete interior/exterior work etc., they are to apply for construction completion inspections to the Organiser via the online portal for the Official Participants, and the Organiser will perform the inspections. If the construction work passes inspections, the Organiser will issue Certificates of Completion and User Permit to the Participants via the online portal for the Official Participants website. The authorisation does not relieve the Participant from its obligations and responsibilities under the law.

**C-193** When Participants complete the interior/exterior decoration work etc., they shall submit the following documents to the Organiser and apply for inspections by seven days prior to the requested date of inspection. This application shall be made after the on-site work is completed and the on-site supervisors confirm that the work complies with approved drawings.

- Application for inspection for Certificate of Completion and User Permit
- Inspection report
- Drawing of completed construction (interior/exterior work etc.)

**C-194** If the Organiser deems that there are violations of Laws and Regulations based on the Final Inspection, it may instruct the Participants to correct the violations, and the Participants shall comply with the instructions.

## 10-7. Permit for Interior/Exterior etc. Removal Work

Participants are to bear responsibility for the removal of their interior/exterior etc.. Participants may commence the removal work after being issued Certificates of Permit for Commencement of Interior/Exterior etc. Removal Work. The Organiser will review the submitted documents and inform Participants of the matters to be pointed out including corrections or give permit through the online portal for the Official Participants. This permit does not exempt Participants from their obligations and responsibilities under the law.

- C-195** To obtain Certificates of Permit for Commencement of Interior/Exterior etc. Removal Work, Participants shall submit to the Organiser the following documents via the online portal for the Official Participants by 15 days prior to the start of the work.
- > Application form for Approval for Commencement of Interior/Exterior etc. Removal Work
  - > Interior/Exterior etc. removal work schedule
  - > Interior/Exterior etc. removal work plan
- C-196** Participants shall not start the work until they receive the Certificate of Permit for Commencement of Interior/Exterior etc. Removal Work.

## 10-8. Procedures for the Completion of Interior/Exterior etc. Removal Work

When Participants complete the interior/exterior etc. removal work, they will apply to the Organiser for inspections for Return of Exhibition Space, and the Organiser will perform the inspections. Participants shall settle the final payments charged by the Organiser before applying for the Final Inspection.

If the interior/exterior etc. removal work passes inspections, the Organiser will issue Certificate for Return of Exhibition Space for the Participant via the online portal for the Official Participants website.

- C-197** When Participants complete their interior/exterior etc. removal work, they shall submit the following documents to the Organiser and apply for inspections via the online portal for the Official Participants by 10 days prior to the requested date of Return of Exhibition Space.
- > Application for Return of Exhibition Space inspection
  - > Final settlement form for Utility fees
  - > Report on completion of interior/exterior etc. removal work
- C-198** If the Organiser deems that there are problems with the work based on the Return of Exhibition Space inspection, such as incomplete removal, they may instruct the Participants to correct the violations, and the Participants shall comply with the instructions.

## Supplementary Information

### List of laws and regulations, ordinances, and standards

The following are main laws and regulations, ordinances, and standards that should be referred to. Participants are to comply with and refer to other relevant standards and such indicated by the Organiser.

Name of law, regulation, ordinance, or standard
- Act on Construction Business and orders/regulations for enforcement of the act
- Building Standards Act and orders/regulations for enforcement of the act
- Osaka Prefectural Ordinance on the Enforcement of the Building Standards Act , Osaka Municipal Ordinance on the Enforcement of the Building Standards Act
- Act on Fire Service and orders/regulations for enforcement of the act - Osaka Municipal Ordinance on Fire Prevention
- Act on Road Traffic and orders/regulations for enforcement of the act
- Act on Waterworks and orders/regulations for enforcement of the act - Osaka Municipal Ordinance on Waterworks and Water Supply - Enforcement Rules for the Osaka Municipal Ordinance on Waterworks and Water Supply - Standards on Construction Design and Work for Water Supply Apparatus
- Act on Sewage - Osaka Municipal Ordinance on Sewage
- Act on Harbour and orders/regulations for enforcement of the act - Guideline on Administrative Handling of Construction Work for Buildings and Structures in the Subdistrict of the Osaka Port Area
- Act on Promoting Easily Accessible Public Transportation and Facilities for the Aged and the Disabled (Barrier-Free Act) and orders/regulations for enforcement of the act - Osaka Prefectural Ordinance on Welfare Communities - Osaka Municipal Government Guidelines for Accessible Urban Planning
- Act on Parking Lot and orders/regulations for enforcement of the act
- Act on Outdoor Advertising and orders/regulations for enforcement of the act - Osaka Municipal Ordinance on Outdoor Advertising
- Act on Labour Standards and orders/regulations for enforcement of the act
- Act on Labour Safety and Health and orders/regulations for enforcement of the act
- Act on the Promotion of Securing Safety and Health for Construction Workers and orders/regulations for enforcement of the act

- Act on Workman's Compensation Insurance and orders/regulations for enforcement of the act
- Technical Guidelines for Construction Machinery and Construction Work Safety
- Act on National Tax Collection
- Basic Act on the Environment and relevant laws and regulations
- Act on Soil Contamination Countermeasures and orders/regulations for enforcement of the act - Osaka Prefectural Ordinance on Maintenance of Living Conditions (provisions relating to soil)
- Act on Water Pollution Prevention and orders/regulations for enforcement of the act - Osaka Prefectural Ordinance on Maintenance of Living Conditions (provisions relating to water quality)
- Act on Noise Regulation and orders/regulations for enforcement of the act - Osaka Prefectural Ordinance on Maintenance of Living Conditions (provisions relating to noise)
- Act on Vibration Regulation and orders/regulations for enforcement of the act - Osaka Prefectural Ordinance on Maintenance of Living Conditions (provisions relating to vibration)
- Act on Air Pollution and orders/regulations for enforcement of the act- Osaka Prefectural Ordinance on Maintenance of Living Conditions (provisions relating to air pollution)
- Basic Act on the Promotion of a Recycle-Oriented Society and orders/regulations for enforcement of the act
- Act on the Promotion of Recycled Resource Use and orders/regulations for enforcement of the act
- Act on Waste Management and Public Cleansing and orders/regulations for enforcement of the act
- Osaka Prefectural Ordinance on the Promotion of a Recycle-Oriented Society
- Construction Material Recycling Act and orders/regulations for enforcement of the act
- Guidelines for the Promotion of Proper Treatment of Construction By-products
- Act on the Promotion of Procuring Eco-Friendly Goods and Services and orders/regulations for enforcement of the act
- Act on the Promotion of Contracts That Are Attentive to Reduction of Greenhouse Gas Emission by the Nation and orders/regulations for enforcement of the act
- Osaka Prefectural Policy on Green Procurement
- Guidelines on Construction Waste Material Processing
- Act on Architects and orders/regulations for enforcement of the act
- Act on Landscape and orders/regulations for enforcement of the act - Osaka Municipal Ordinance on Urban Landscape
- Act on Entertainment Facilities and orders/regulations for enforcement of the act

- Act on Food Sanitation and orders/regulations for enforcement of the act

- Act on the Measures by Large-Scale Retail Stores for Preservation of Living Environment and orders/regulations for enforcement of the act

- Standards on Administrative Handling of Establishing Medium-Scale Retail Stores

## List of notifications to respective government bodies

The lists below describe major notifications to be submitted to respective government bodies.

These are provided for your reference. You may need to prepare and submit notifications other than these if required.

Notifications that the Organiser will submit as of plan

Name of notification	Submit to	Period of submission	Remarks (those applicable to notification)
<b>Building Standards Act and orders/regulations for enforcement of the act, Osaka Prefectural Ordinance on the Enforcement of the Building Standards Act</b>			
Application for Building Permit/Final Inspection (including reviews of relevant provisions)	Construction supervision department, Planning and Coordination bureau, City of Osaka / confirmation auditing bodies	By 7 days prior to inspections	Structures that have obtained confirmation certificates
Notification on removal of structures	Construction supervision department, Planning and Coordination bureau, City of Osaka	By the commencement of demolition	Demolition of structures exceeding 10 m <sup>2</sup> in size
<b>Act on Fire Service and orders/regulations for enforcement of the act, Osaka Municipal Ordinance on Fire Prevention</b>			
Notification on commencement of major equipment instalment work Notification on Design of Fire Fighting Equipment, etc. Notification on the Design of Fire Fighting Equipment Designed for Preventing Fire Spreading Through Ductwork	Konohana fire station of Osaka Municipal Fire Department	By 10 days prior to commencement of construction	Construction work for instalment Fire Fighting Equipment, etc.
Notification on installation of Fire Fighting Equipment, etc.	Same as above	Within 4 days from completion of construction	When installing Fire Fighting Equipment, etc. for structures applicable to fire prevention
Notification on start of use of structures applicable to fire prevention	Same as above	By 7 days prior to the start of use	When starting the use of structure applicable to fire prevention
Notification on appointment of fire control administrator Notification on the preparation of fire fighting plan	Same as above	By the start of the use of structures applicable to fire prevention	Structures applicable to fire prevention that require fire control administrators
Notification on storage of small-quantity hazardous items or designated combustible materials	Same as above	By 7 days prior to handling	When handling specified or more volume of small-quantity hazardous materials or designated combustible materials
Notification on offices prepared at sites for construction work	Same as above	By 3 days prior to doing so	When preparing offices at sites for construction work



Notification on instalment of fuel cell, transformer, rapid charger, power generator, and storage cell equipment	Same as above	By 5 days prior to starting the instalment construction	When installing the equipment indicated on the left
Notification on holding events	Central fire station of Fire Department, City of Osaka	By 3 days prior to doing so	(Submitted by the Organiser)
<b>Act of Waterworks and orders/regulations for enforcement of the act, Osaka Municipal Ordinance on Waterworks and Water Supply</b>			
Construction application form and construction work approval application for water supply apparatus	Water Service Installation Department, Engineering Division, Waterworks Bureau, City of Osaka	Before commencing construction work	(Submitted by the Organiser)
Notification on construction completion	Same as above	When completing construction work	(Submitted by the Organiser)
Notification on commencing use	Same as above	Before use	(Submitted by the Organiser)

Name of notification	Submit to	Period of submission	Remarks (those applicable to notification)
<b>Act on Sewage and orders/regulations for enforcement of the act, Osaka Municipal Ordinance on Sewage</b>			
Application form for confirmation of water drainage equipment plans	*Facility Management Department, Sewerage Division, Public Works Bureau, City of Osaka, *Clearwater OSAKA Corporation	Individual confirmation	(Submitted by the Organiser)
Notification on detoxification facility instalment plans	Facility Management Department, Sewerage Division, Public Works Bureau, City of Osaka	Beforehand	When installing detoxification facilities or taking necessary measures to enable water quality at water drainage standard levels or lower
<b>Act on Outdoor Advertising, Osaka Municipal Ordinance on Outdoor Advertising</b>			
Application for outdoor advertising permits	Management Department, General Affairs Division, Public Works Bureau, City of Osaka	3 weeks before commencing construction work	When installing outdoor advertising
Notification on construction completion	Management Department, General Affairs Division, Public Works Bureau, City of Osaka	When completing instalment	When installing outdoor advertising
<b>Act on Labour Standards and orders/regulations for enforcement of the act</b>			
Applicable business report	Nishinoda Labour Standards Inspection Office	After commencing business, without delay	When commencing business applicable to the Act on Labour
Notification on agreement concerning overtime and holiday working	Nishinoda Labour Standards Inspection Office	Before commencing, without delay	When employees are required to work overtime for one day and a certain period of more than one day or work on holidays
Notification on agreement concerning one-year unit variable working hour systems	Nishinoda Labour Standards Inspection Office	Before commencing, without delay	Business locations implementing one-year unit variable working hour systems

Application form for permit concerning intermittent day or night shift working	Nishinoda Labour Standards Inspection Office	Before commencing, without delay	When being exempted in terms of working hours due to intermittent day or night shifts
Notification on work regulations	Nishinoda Labour Standards Inspection Office	After establishing, without delay	Business locations that use 10 or more workers at all times
<b>Act on Labour Safety and Health and orders/regulations for enforcement of the act</b>			
Notification on construction work	Nishinoda Labour Standards Inspection Office	Differs according to content of plan	When commencing work defined in Article 88 of the Act on Labour Safety and Health
Notification on instalment of structures and machines	Nishinoda Labour Standards Inspection Office	When commencing constructions	When installing, transferring, or changing machines specified in Appendix Table 7 of the Act on Labour Safety and Health
Report on commencement of business as a special principal employer	Nishinoda Labour Standards Inspection Office	When commencing constructions	If workers of the special principal employer and related contract workers work at the same location
Notification on representative of joint businesses	Nishinoda Labour Standards Inspection Office	When commencing constructions	When establishing joint businesses

Name of notification	Submit to	Period of submission	Remarks (those applicable to notification)
<b>Act on Labour Safety and Health and orders/regulations for enforcement of the act</b>			
Report on appointment of general safety and health administrator, safety administrator, health administrator, and corporate physician	Nishinoda Labour Standards Inspection Office	When commencing constructions	Business locations at which a prespecified number or more workers work
Accident report	Nishinoda Labour Standards Inspection Office	As needed during constructions	When accidents occur
Report on workers' death and injuries	Nishinoda Labour Standards Inspection Office	As needed during constructions	When occupational hazards occur
Notification on instalment of cranes	Nishinoda Labour Standards Inspection Office	As needed during constructions	When installing cranes of 3 tonnes or more (1 tonne or more for stacker methods) in lifting load
Report on instalment of derricks	Nishinoda Labour Standards Inspection Office	As needed during constructions	When installing derricks of 0.5 tonnes or more and less than 2 tonnes in lifting load
Report on instalment of elevators and simple lifts	Nishinoda Labour Standards Inspection Office	As needed during constructions	When installing elevators or simple lifts of 0.25 tonnes or more and less than 1 tonne in loading capacity
Notification on instalment of construction lifts	Nishinoda Labour Standards Inspection Office	As needed during constructions	When installing construction lifts of 0.25 tonnes or more in loading capacity and 18 m or more in guide rail height
Report on results of periodic health examinations	Nishinoda Labour Standards Inspection Office	As needed during constructions	Business operators using 50 or more workers at all times

<b>Act on National Tax Collection and orders/regulations for enforcement of the act</b>			
Labour insurance: notification on establishment of insurance relations	Industrial accident insurance: Umeda Public Employment Security Office Employment insurance: Nishinoda Labour Standards Inspection Office	Within 10 days from the day of establishing insurance relations	-
Labour insurance: application form on estimated insurance premium and payment statements	Industrial accident insurance: Umeda Public Employment Security Office Employment insurance: Nishinoda Labour Standards Inspection Office	Within 50 days from the day of establishing insurance relations	-
Labour insurance: permit application form for subcontractors serving as business operators	Nishinoda Labour Standards Inspection Office	Within 10 days from the day of establishing insurance relations	When deeming subcontract projects as independent constructions and establishing insurance relations
Workman's compensation insurance: notification on appointment of agents	Nishinoda Labour Standards Inspection Office	Promptly each time a representative is appointed	When having agents process administrative work for labour insurance

Name of notification	Submit to	Period of submission	Remarks (those applicable to notification)
<b>Soil Contamination Countermeasures Act and orders/regulations for enforcement of the act, Osaka Prefectural Ordinance on Maintenance of Living Conditions (provisions relating to soil)</b>			
Notification on change in ground characteristics within districts where change in ground characteristics is required to be reported	Submitted by the Organiser	-	(Submitted by the Organiser)
Report on history of use of 3000 m <sup>2</sup> or larger grounds that are altered in terms of characteristics	Submitted by the Organiser	-	(Submitted by the Organiser)
Notification on shipping out contaminated soil	Environmental Management Department, Environmental Management Division, Environment Bureau, City of Osaka	By 14 days prior to the day of commencement	When shipping out soil from districts requiring measures
<b>Act on Special Measures Concerning Conservation of the Seto Inland Sea</b>			
Application form for permit on installing (changing) special facilities	Facility Management Department, Sewerage Division, Public Works Bureau, City of Osaka	By the time of instalment	Business sites that emits maximum water volume of 50 m <sup>3</sup> or more per day to public water areas
<b>Act on Noise Regulation and orders/regulations for enforcement of the act, Osaka Prefectural Ordinance on Maintenance of Living Conditions (provisions relating to noise)</b> <b>Act on Vibration Regulation and orders/regulations for enforcement of the act, Osaka Prefectural Ordinance on Maintenance of Living Conditions (provisions relating to vibration)</b>			
Notification on performance of special construction work	Seibu Environment Conservation Group, Environmental Management	By 7 days prior to commencing construction work	When performing special construction work that uses construction machines such as pile drivers or backhoes

	Department, Environmental Management Division, Environment Bureau, City of Osaka		
<b>Act on Air Pollution and orders/regulations for enforcement of the act</b>			
Notification of the Works Involving the emissions of specified particulates (Report on the preliminary asbestos investigation)	Seibu Environment Conservation Group, Environmental Management Department, Environmental Management Division, Environment Bureau, City of Osaka	Before starting construction	Demolition of structures that are 80 m <sup>2</sup> or more in floor area Repairs that are 1 million yen or more in contract fees
<b>Construction Material Recycling Act and orders/regulations for enforcement of the act</b>			
Notification pursuant to the Act on Construction Material Recycling	Building Verification Department, Building Guidance Division, Planning and Coordination Bureau, City of Osaka	By 7 days prior to commencing construction work	Demolition: 80 m <sup>2</sup> or more in floor area Construction: 500 m <sup>2</sup> or more in floor area
<b>Act on Waste Management and Public Cleansing and orders/regulations for enforcement of the act</b>			
Report on the status of delivery of management slips for industrial waste	Industrial Waste Regulation Group, Environmental Management Department, Environmental Management Division, Environment Bureau, City of Osaka	Earliest June 30 after the end of the previous fiscal year	Report once a year of the summary of the results for the previous fiscal year (April to March)
Industrial waste treatment plan	Same as above	June 30 in the fiscal year for which the plan should be notified	Entity that should make a notification is the business operator whose total amount of industrial waste generated from each work place (site) in Osaka city in the previous fiscal year is 1,000 tons or more.
Implementation status report on Industrial waste treatment plan	Same as above	June 30 of the next fiscal year after the fiscal year for which the plan was submitted	Entity that should make a notification is the business operator who submitted the "Industrial Waste Treatment Plan" of the fiscal year.
<b>Consultation with Osaka Metro on contiguous construction</b>			
Consultation on contiguous railway construction of the North Port Techno Port Line	Planning Division, Osaka Ports and Harbours Bureau	when needed	In case within 30m from the position of the underground shield of the North Port Techno Port Line
<b>Road Act and orders/regulations for enforcement of the act</b>			
Application for permit to traffic of special vehicles	Coordination Department, Roads, Streets, and Rivers Division, Public Works Bureau, City of Osaka (in case of traffic on a road under the Act on Road, traffic both on a road under the Act on Road Law and on a port road in once)  Facility Management Division, Planning and Maintenance Department, Osaka Ports and Harbours Bureau (in case of traffic on port roads only)	By 8 weeks before the traffic start date (*)	When traveling on the road with a special vehicle  (* ) If it is less than 8 weeks before the traffic start date, please contact the submission destination.

**Contact**

The Official Participants can send inquiries concerning the content of this Guide or uncertainties concerning procedures to the Organiser using the Queries function in the online portal for the Official Participants.

If you have any trouble using the online portal for the Official Participants, please contact us by email to ; [participant@expo2025.or.jp](mailto:participant@expo2025.or.jp)



**Bureau  
International  
des Expositions**

Japan Association for the 2025 World Exposition